



Technický a skúšobný ústav stavebný, n. o.
Building Testing and Research Institute
Studená 3
821 04 Bratislava
Slovak Republic
Phone: +421 2 49228101
E-mail: sternova@tsus.sk
Website: www.tsus.sk



European Technical Assessment

**ETA 18/0312 – version 01
of 17/09/2018**

General Part

Technical Assessment Body issuing the ETA and designated according to Article 29 of the Regulation (EU) No 305/2011: **Technický a skúšobný ústav stavebný, n. o.**

Trade name of the construction product

Prefabricated timber building kits made of SE structural insulation panels “SE SIP”

Product family to which the construction product belongs

Product area code: 34
Building Kits, Units and Prefabricated elements

Manufacturer

SIPEUROPE s.r.o.
Novozámocká 353
951 12 Ivanka pri Nitre
Slovak Republic
<http://sipdom.sk/>

Manufacturing plant

SIPEUROPE s.r.o.
Nitrianska cesta 1948/154
951 31 Močenok
Slovak Republic

This European Technical Assessment contains

39 pages including 7 annexes which form an integral part of this assessment.

This European Technical Assessment is issued in accordance with regulation (EU) No 305/2011, on the basis of

ETAG 007, edition 2012, used as European Assessment Document (EAD).

This version replaces

—

Translations of this European Technical Assessment in other languages shall fully correspond to the original issued document and should be identified as such.

Communication of this European Technical Assessment, including transmission by electronic means, shall be in full (excepted the confidential Annex(es) referred to above). However, partial reproduction may be made, with the written consent of the issuing Technical Assessment Body – Technický a skúšobný ústav stavebný, n. o. (TSÚS). Any partial reproduction has to be identified as such.

Specific part

1 Technical description of the product

Buildings with timber frame construction and SIP panels – Prefabricated timber building kits made of SE structural insulation panels “SE SIP”, are pre-designed construction kits prepared in manufacturing plant and are delivered as a package to be assembled on site.

Building kits, covered by this ETA consist of main building parts such as walls, floors, ceilings and roof structures described in this ETA. The load-bearing components of the kits are made of structural timber (spruce, fir, pine, larch), structural finger jointed solid timber, glued laminated timber and glued massive timber and SE structural insulation panels “SE SIP”. The components of the structural parts of the kit are fastened by metal fasteners such as nails screws, bolts and like that. Types, number and placement of the fasteners is individually designed for each kit according to structural details.

Detailed description of constructions of walls, floor, roof and SE structural insulation panels “SE SIP” are given in Annex 1.

The windows, doors, roof covering, internal lining, internal surfaces in wet areas (such as bathroom or toilet, etc.) and final surface finishing of the floors can be part of the kit. This technical assessment does not determine requirements for these products.

Complementary parts of the building like substructure, internal fittings, technical installation for water, ventilation, heating and other technical equipment necessary for building to form a complete house are not part of the ETA.

Materials and components which are part of the kit and their specifications are given in Annex 1. Detailed materials specifications are given in Annex 2.

The essential construction details of the kit including the assembly details on the site and conditions for installation of the kit in the works are given in Annex 7.

2 Specification of the intended use(s) in accordance with the applicable European Assessment Document (hereinafter EAD)

2.1 Intended use

Building kits are mainly intended to be used as a residential buildings and cottages. Other possible uses are as shops, hotels, restaurants and other types of buildings when the performance requirements are applicable. Intended use of the building kit shall be individually considered according to legislation in the county of use. The number of the full storeys shall be in accordance with local regulations valid for construction site.

The kits are intended to be placed on all types of substructure ended by concrete slab, reinforced concrete slab or other construction suitable for this purpose.

The limitations of intended use include regions where the heavy rain or snow with combination of extreme wind conditions may occur. Such areas might be for example high mountains or coastal areas.

The wood components are not chemically treated for use in regions with possible termite attacks. The chemical treatment shall be done according to local regulations for such use. This European Technical Assessment does not involve methods of chemical treatment of the kit.

Seismic loads shall be taken in account if the kit will be used in region where the seismic activity may occur.

The modifications of the kit might be necessary according to special customer demands, specific climate conditions, national regulations or other regulation valid for construction site. The modifications shall be described in design documentation of the kit.

2.2 Intended working life of the construction product

Provisions made in this European Technical Assessment are based on an assumed intended working life of the building kit for the intended use of:

- 50 years for the load-bearing structure and for non-accessible components and materials;
- 25 years for repairable or replaceable components and materials like cladding, roofing materials and integrated components, e.g. doors and windows.

The kits should be maintained according to manufacturer recommendations to reach intended working life

The indications given on the working life cannot be interpreted as a guarantee given by the kit manufacturer or the Technical Assessment Body, but are to be regarded only as a means for choosing the appropriate product in relation to the expected, economically reasonable working life of the works.

3 Performance of the product and reference to the methods used for its assessment

3.1 Mechanical resistance and stability (BWR 1)

In general, the kits are delivered according to the “made to measure” principle. The load-bearing components of the kit are individually designed. An individual mechanical resistance and stability report shall be prepared for each building kit. Report shall contain assessment of all load-bearing components of the kit. Components of the kit shall be assessed according to EN 1995-1-1, EN 1990, as well as relevant parts of EN 1991 supported by relevant standards and harmonized product standards.

Wall, floors and roof components necessary to ensure mechanical resistance and stability, description of materials and their dimensions are given in Annex 1. Detailed material specifications are given in Annex 2, Table 1.

The foundations are not part of the kit. The individual loads and conditions of each kit should be taken in account for the structural design of the foundations or design of constructions that the kit will be fitted on.

Seismic actions shall be taken in account if the kit will be used in region where the seismic activity may occur. Resistance against seismic actions shall be assessed according to relevant part of EN 1998 and other information on resistance against seismic actions based on the various national determined parameters given in national annexes or other national regulations may be taken into account for the specific structural design and for each individual works.

Loadbearing components made of structural timber should full requirements according to EN 14081-1. Loadbearing components made structural finger jointed solid timber should full requirements according to EN 15497. Glued laminated timber and glued solid timber used in loadbearing constructions should fulfil requirements according to EN 14080. Strength classes according to EN 338 and EN 14080 given in individual mechanical resistance and stability report should be followed for particular kit.

Assessment and declaration of mechanical resistance and stability shall be done according to method 3a or method 3b indicated in EC Guidance Paper L – Application and use of Eurocodes. The manufacturer shall ensure that:

- reference is made in an unambiguous way to the purchaser's structural design documents for the each works in case of method 3a;
- reference is made in an unambiguous way to the manufacturer's structural design documents for the specific parts of the each works according to the order in case of method 3b.

Maximum moisture content of timber components during manufacturing processes and storage should not exceed 18 %. The moisture content of structural finger jointed solid timber, glued laminated timber and glued massive timber cannot exceed 16 %. Moisture content of other timber components and wood-based components shall meet requirements according to corresponding technical specification.

Dimension tolerances of cross-sections of columns, beams, purlins and other structural members made of timber, finger jointed solid timber, glued laminated timber and glued massive timber shall fulfil requirements of tolerance class 1 according to EN 336. Also the following tolerances shall be kept:

- external, internal and floor "SE SIP" panel: length ± 5 mm
height ± 5 mm
thickness ± 3 mm
- building openings and openings in "SE SIP panels": width ± 2 mm
height ± 2 mm
- other wood structural components: width of the cross-section ± 2 mm
height of the cross-section ± 2 mm
length ± 5 mm

"SE SIP" panels have to be manufactured in such way that the OSB boards of the skin are area-wide glued to surface of the insulation core.

Mechanical resistance of loadbearing walls and SIP panel floor is given in Annex 3.

3.2 Safety in case of fire (BWR 2)

3.2.1 Reaction to fire of materials and components

The classification of the materials and components of the kits according to EN 13501-1 is given in Annex 2, Table 1. Those materials which are deemed to satisfy all requirements for the performance characteristic without need for testing according to Commission Decisions are given in Annex 2 with reference to the related Commission Decision.

3.2.2 Resistance to fire

Classification of resistance to fire of kits building elements according to EN 13501-2 is given in Table 5, 6 and 7 in annex 4. Detailed description of building elements is given in Annex 1.

3.2.3 External fire performance of the roof covering

No performance assessed.

3.3 Hygiene, health and environment (BWR 3)

3.3.1 Vapour permeability and moisture resistance

Vapour permeability and moisture resistance was determined according to EN ISO 13788 as acceptable for intended use with regard to the geographical restrictions given in Clause 2.1. Building elements shall be assumed in project documentation with regard to vapour condensation taking in account specific indoor climate conditions in summer and winter.

3.3.2 Watertightness

3.3.2.1 External envelope

Watertightness of the external envelope in consideration of water from rain and melting snow including driving rain and snow has been assessed to be adequate for the intended use. Standard construction details are given in Annex 7.

The limitations of intended use due to water tightness are given for the regions where heavy rain or snow in combination with extreme wind condition may occur, e. g. high mountains or coastal areas.

3.3.2.2 Internal surfaces

No performance assessed.

3.3.3 Release of dangerous substances

The kits comply with the provision of Guidance paper H¹ about dangerous substances taking in account Regulation (EC) No 1272/2008 and release scenarios according to EOTA TR 034². Content of formaldehyde in finger joined solid timber, glued laminated timber and glued massive timber, OSB boards and wood-based products is assessed as class E1. The content of pentachlorophenol (PCP) of the wood-based products is less than 5 ppm. The manufacturer issued declaration about content of dangerous substances. In addition, each country may have national requirements (e.g. national legislation, regulations and provisions) applicable to the intended use of the kit that should be complied with.

Chemically treated wood will be used only if national legislation demands it. Any chemically treated wood shall follow national provisions and provisions of the biocide directives.

3.4 Safety in use (BWR 4)

3.4.1 Slipperiness of floor finishes

No performance assessed.

3.4.2 Impact resistance

Walls given in Annex 1 have satisfactory impact resistance for intended use given in Clause 2.1.

No performance assessed for impact resistance of the floors.

3.5 Protection against noise (BWR 5)

3.5.1 Airborne sound insulation

No performance assessed.

3.5.2 Impact sound insulation of floors

No performance assessed.

3.5.3 Sound absorption

No performance assessed.

3.6 Energy economy and heat retention (BWR 6)

3.6.1 Thermal resistance

Heat transfer resistance values R_T and values of thermal transmittance U of the kit building elements are given in Annex 5, Table 8 and 9.

¹ Guidance Paper H: A harmonised approach relating to dangerous substances under the Construction Products Directive, edition September 2002.

² EOTA TR 034: General ER 3 Checklist for ETAGs/CUAPs/ETAs – Content and/or release of dangerous substances in products/kits, edition March 2012.

3.6.2 Air permeability

Air permeability of building elements according to construction details given in Annexes 1 and 7 was assessed as an acceptable for intended use.

3.6.3 Thermal inertia

No performance assessed.

3.7 Sustainable use of natural resources (BWR 7)

No performance assessed.

3.8 Durability, serviceability and identification

3.8.1 Aspects of durability

The kits have been assessed to have adequate durability for intended use according to Clause 2.1 taking in account intended working life given in Clause 2.2.

The kits are standardly made of structural timber, finger joined solid timber, glued laminated timber and glued massive timber. The spruce wood (*Picea abies*) is used for the production of the wood components. Components can be manufactured also with same or higher natural durability as spruce wood, e.g. fir (*Abies alba*), pine (*Pinus silvestris*) and larch (*Larix decidua*). Components made of wood species with the higher durability than spruce are suitable for use in direct contact with masonry or concrete components or where the higher stress due to climate and weather conditions is expected.

Wood loadbearing components and wood components exposed to external weather conditions can be chemically treated in accordance with Clause 3.3.3.

The adequacy of the use according to EN 335 for wood and wood-based products used in the kit is given in Annex 6, Table 10.

The adequacy of the use according to EN 1995-1-1 for the fasteners used in the kit is given in Annex 6, Table 11.

The use of the kit in regions where termite attack may occur is impermissible without additional chemical treatment.

The additional measures of the works shall be taken to provide adequate durability if the kit will be used in climate condition with often incidence of driving rain and snow.

The assumed intended working life as stated in Clause 2.2 requires regular maintenance as specified by the manufacturer instructions which is attached to every delivered kit (see 5.8).

3.8.2 Aspects of serviceability

The deformations due to limit states shall be declared for each loadbearing component of the kit by calculation according to EN 1995-1-1. The assessment of maximum allowed deformations shall be according to valid standards and national regulations of country of use. The assessment of maximal deformations and stiffness of the kit is part of the individual design according to Clause 3.1.

3.8.3 Identification

The identification parameters and references to products specification for identifying the materials and components of the kit are given in Annex 2, Table 1.

4 Assessment and verification of constancy of performance (hereinafter AVCP) system applied, with reference to its legal base

According to the European Commission Decision 99/455/EC³, the AVCP system 1 applies (further described in Annex V to Regulation (EU) No 305/2011).

The manufacturer shall draw up the declaration of performance and determine the product-type on the basis of the assessments and verifications of constancy of performance carried out under the system 1 on the basis of:

- (a) The manufacturer shall carry out:
 - (1) Factory production control;
 - (2) Further testing of samples taken at the manufacturing plant by the manufacturer in accordance with the prescribed test plan.
- (b) The notified product certification body shall decide on the issuing, restriction, suspension or withdrawal of the certificate of constancy of performance of the construction product on the basis of the outcome of the following assessments and verifications carried out by that body:
 - (3) An assessment of the performance of the construction product carried out on the basis of testing (including sampling), calculation, tabulated values or descriptive documentation of the product;
 - (4) Initial inspection of the manufacturing plant and of factory production control;
 - (5) Continuing surveillance, assessment and evaluation of factory production control.

Continuing surveillance, assessment and evaluation of factory production control has to be performed at least twice a year.

5 Technical details necessary for the implementation of the AVCP system, as provided for in the applicable EAD

In order to help the Notified Body to make an evaluation of conformity, the Technical Assessment Body (TAB) issuing the ETA shall supply the information detailed below. This information together with the requirements given in EC Guidance Paper B will generally form the basis of the factory production control (FPC).

This information shall initially be prepared or collected by the Technical Assessment Body and shall be agreed with the manufacturer. The following gives guidance on the type of information required:

1) The ETA

Where confidentiality of information is required, this ETA makes reference to the manufacturer's technical documentation which contains such information.

2) Basic manufacturing process

The basic manufacturing process is described in sufficient detail to support the proposed FPC methods.

Components for partitions are normally manufactured using conventional techniques. Any critical process or treatment of the components affecting performance shall be highlighted.

3) Product and materials specifications

The manufacturer's documentation includes:

- detailed drawings (possibly including manufacturing tolerances);
- incoming (raw) materials specifications and declarations;
- references to European and/or international standards;
- technical data sheets.

³ Official Journal of the European Communities L 178, 14.7.1999, p. 56.

5.1 Determination of the product-type on the basis of type testing, type calculation, tabulated values or descriptive documentation of the product

The results of tests, calculations and assessments performed as a part of the assessment for this European Technical Assessment shall be used unless there are changes in the production line or plant. In such cases the necessary type testing has to be agreed between the manufacturer and the TSÚS.

5.2 Control plan and factory production control

The manufacturer shall exercise permanent internal control of production. All the elements, requirements and provisions adopted by the manufacturer shall be documented in a systematic manner in the form of written policies and procedures. This production control system shall insure that the product is in conformity with this European Technical Assessment.

The manufacturer shall only use materials stated in the technical documentation⁴ of this European Technical Assessment. The factory production control shall be in accordance with the control plan which is part of the technical documentation of this European Technical Assessment.

The results of factory production control shall be recorded and evaluated in accordance with the provisions of the Control Plan.

5.3 CE marking

The CE marking shall be affixed visibly, legibly and indelibly to the kit or to a label attached to it. Where this is not possible or not warranted on account of the nature of the kit, it shall be affixed to the packaging or to the accompanying documents.

The CE marking shall be followed by:

- two last digits of the year in which it was first affixed;
- name and the registered address of the manufacturer, or the identifying mark allowing identification of the name and address of the manufacturer easily and without any ambiguity;
- unique identification code of the product-type;
- reference number of the declaration of performance;
- level or class of the performance declared;
- reference to the harmonised technical specification applied (number of the ETA);
- identification number of the notified body;
- intended use as laid down in the harmonised technical specification applied.

5.4 Packing, transport and storage of the kit

The manufacturer's manual for the packaging, transport and storage of the kit shall be followed.

The components and materials of the kit shall be protected from weather exposure and mechanical damage during transport and storage.

The components and materials cannot be lifted or stored in such a way that will cause damage or excessive deformation to them.

⁴ The technical documentation of this European Technical Assessment has been deposited at the TSÚS.

5.5 Design of the kit

The production of components for the building kits shall only be done on the basis of a design work made for each individual building where the kits are part of the works. The design work shall be based on the relevant local building regulations for the works, and normally take into account the following:

- requirements for structural design;
- fire safety requirements;
- special local requirements related to health and the environment;
- safety in use;
- noise protection requirements;
- energy saving requirements.

5.6 Manufacture of the kit

The kit is manufactured in accordance with the provisions of the European Technical Assessment using the manufacturing process as identified in the inspection of the manufacturing plant and factory production control by the notified body and laid down in the technical documentation.

5.7 Assembly and installation of the kit

The components of the kit shall be checked before installation that they have not been damaged during transportation or storage. Damaged components and materials shall be replaced by good ones.

The manufacturer has an individual installation guide for every kit type at his disposal. Every individual installation guide contains all important aspects related to kit installation and construction site such as:

- assembly methods and necessary equipment;
- standard assembly joints and special joints designed for specific kits;
- completion of joints between kit components (structural fixing, weather sealing, etc.);
- additional materials and components applied on the site, which are a precondition for the fitness of use of the kit;
- measures to be carried out due to setting of walls;
- details of stiffening of the kit;
- protection against weather during installation.

The individual installation guide contains a general installation manual.

The completed building (the works) shall comply with the building regulations (regulations on the works) applicable in the member state in which the building is built. The procedures foreseen in the member state for demonstrating compliance with the building regulations shall also be followed by the entity held responsible for this act. The ETA for building kits does not amend this process in any way.

This European Technical Assessment does not comprise the substructure of the building. The substructure is not part of the kit. The substructure shall be individually designed according to the local building regulations to fit the building site. The maximum required tolerances of the substructure dimensions and levelling are ± 10 mm. The level of the substructure with regard to the surrounding soil shall be chosen so, that there is no adverse effect to the durability of the construction, which depends on the local conditions.

5.8 Use, maintenance, repair

It is the responsibility of the manufacturer to ensure that each delivery contains proper information for the use of the kit including general guidance on the basis of the European Technical Assessment.

The components of the kit shall be regularly inspected and maintained in accordance with maintenance instructions which follow every delivered kit.

Technický a skúšobný ústav stavebný, n. o.
Building Testing and Research Institute
Studená 3, 821 04 Bratislava, Slovak Republic

On behalf of the Technický a skúšobný ústav stavebný, n. o.
Bratislava, 17th September 2018



prof. Ing. Zuzana Sternová, PhD.
Head of Technical Assessment Body

Annexes

- Annex 1 Detailed description of “SE SIP” panels composition of external wall, internal walls, floor and roof constructions
- Annex 2 Materials and components specifications
- Annex 3 Mechanical resistance of the constructions
- Annex 4 Fire resistance of the constructions
- Annex 5 Thermo-technical parameters of the constructions
- Annex 6 Natural durability of wood and use classes of components and fasteners
- Annex 7 Construction details of the kits

Annex 1

Detailed description of “SE SIP” panels composition of external wall, internal walls, floor and roof constructions

SE structural insulation panels “SE SIP”

SE structural insulation panels “SE SIP” are made of insulation core and outer skin. Core of the panel can be made of expanded polystyrene (EPS), expanded polystyrene with graphite or rigid polyurethane foam (PU). Skin of the panel can be made of 15 mm thick OSB/3 or OSB/4 boards or 12,5 mm thick gypsum fibre boards for structural use (the Vidiwall boards). Skin is area-wide glued to insulation core by one component polyurethane glue for structural joints. Glue must be suitable at least for use class 2 or higher. Standard thicknesses of the panels are given in Figures 1, 2 and 3. It is possible to use also other thicknesses of the “SE SIP” panels from the standard ones for the kits.

Dimensions in mm

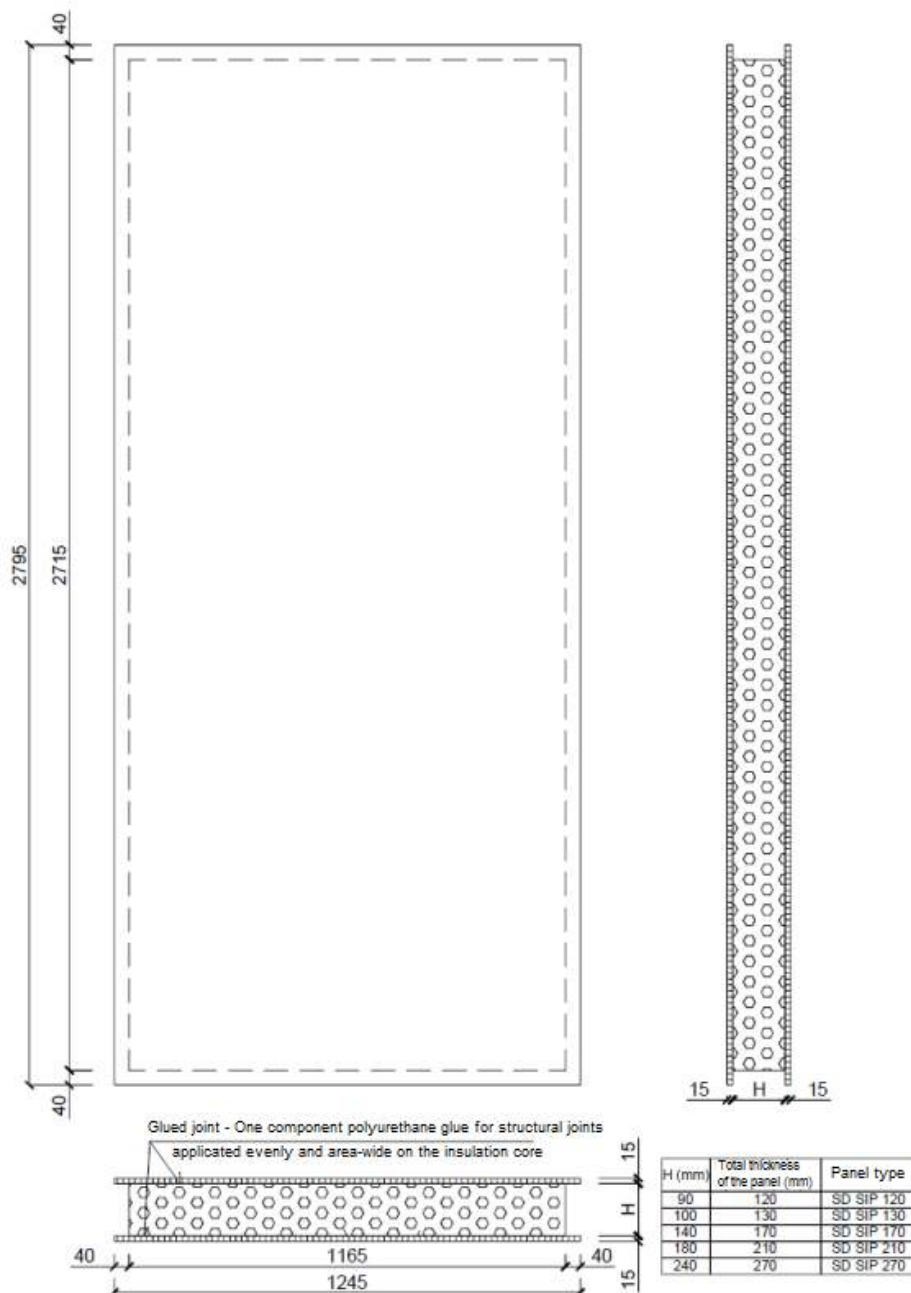

Figure 1 – Standard format of the “SE SIP structural insulation panels with OSB skin

Dimensions in mm

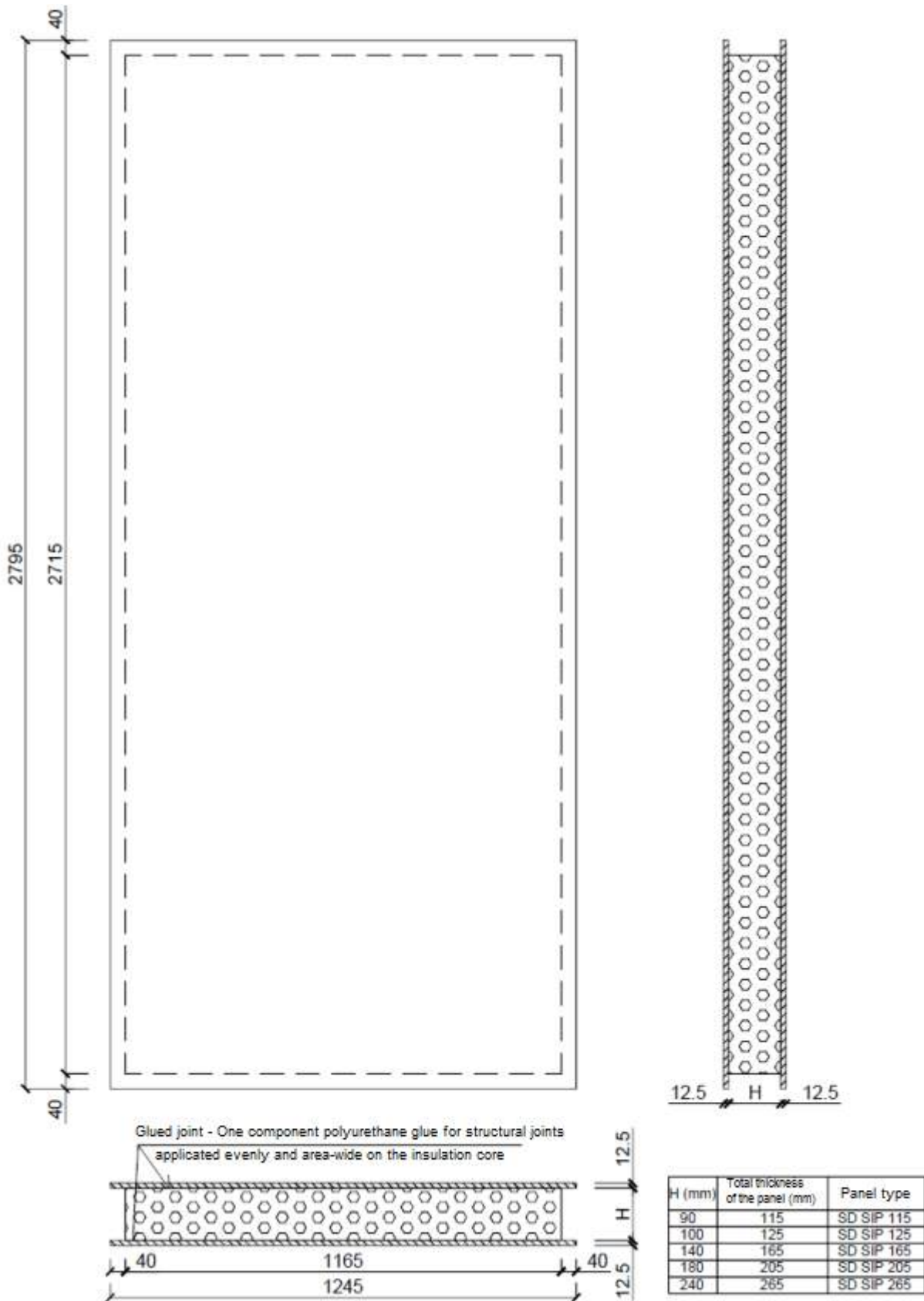

Figure 2 – Standard format of the “SE SIP structural insulation panels with skin made of gypsum fibreboard boards for structural use “Vidiwall”

Dimensions in mm

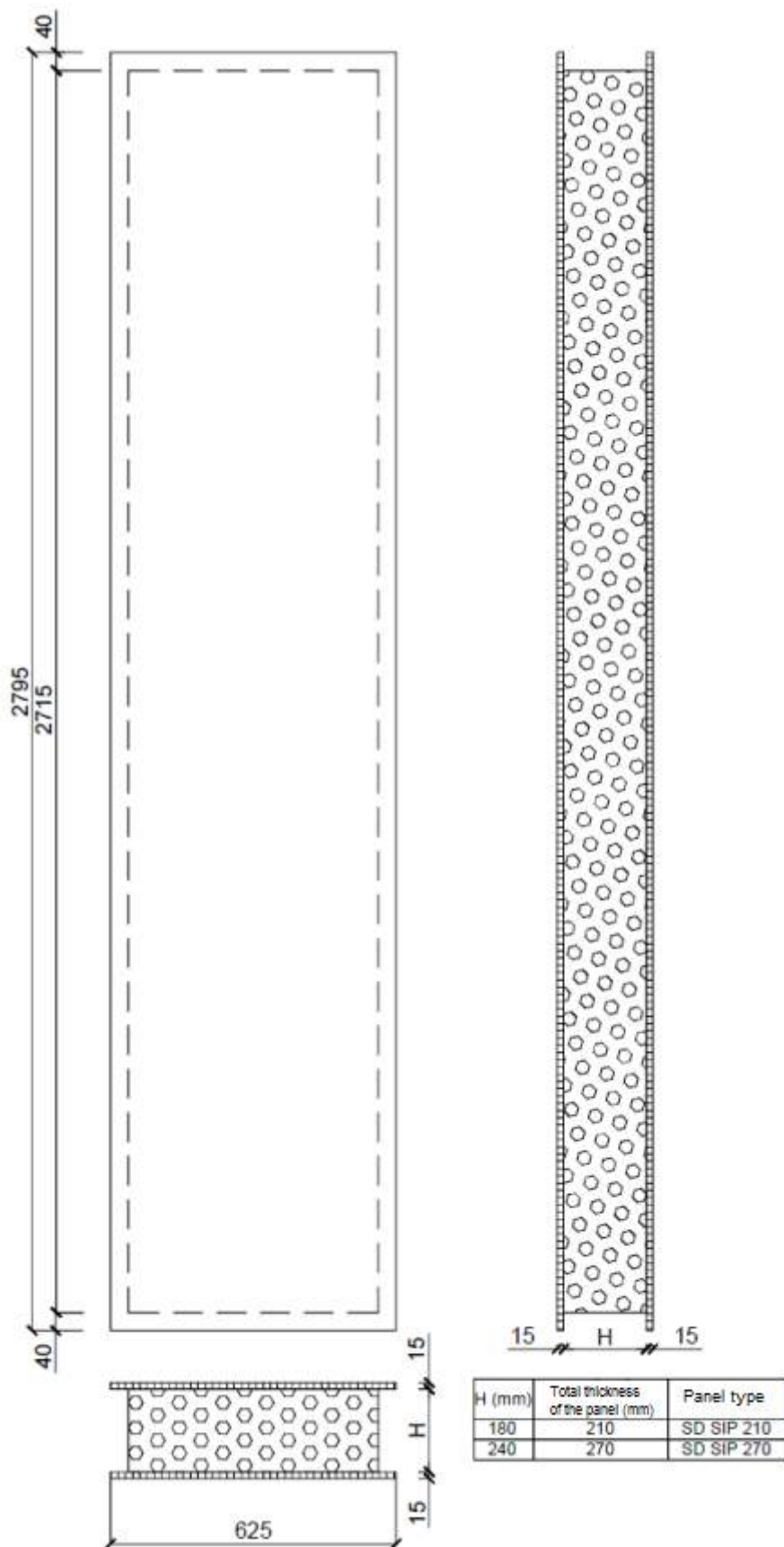
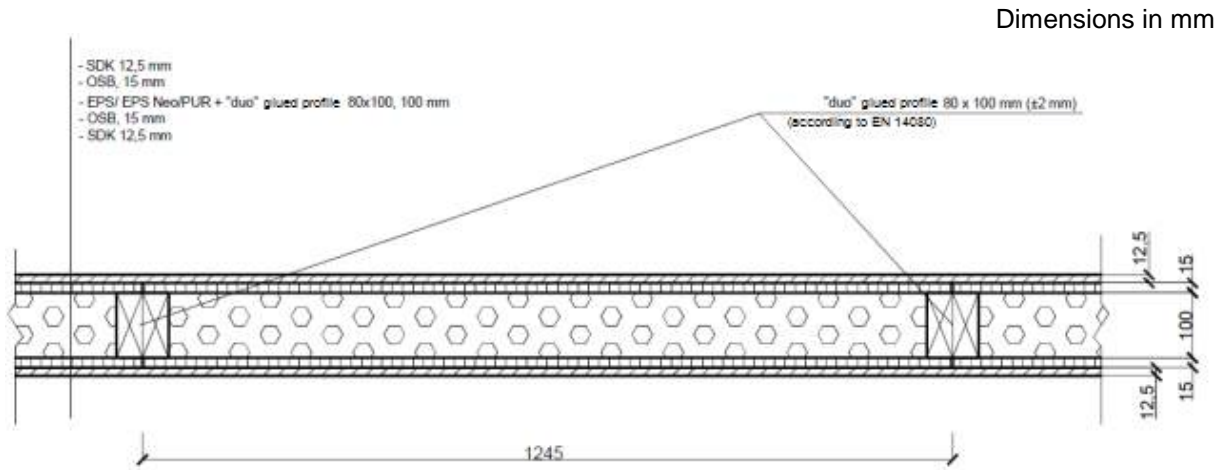

Figure 3 – Half size format of the “SE SIP structural insulation panels with OSB skin for floor and roof constructions

Internal dividing walls

The main part of the construction of the internal dividing walls is constituted by wood loadbearing elements and SE SIP panels. Sheathing of the panels is from gypsum plasterboards. Loadbearing internal dividing walls are made of panels at least SE SIP 115 (skin of the panels made of 12,5 mm thick gypsum fibreboards) or SE SIP 120 (skin of the panels made of 15 mm OSB boards) or SE SIP panels with greater thickness can be used.



Layer	Description	Layer thickness (mm)
INT	–	–
1	Surface board, gypsum plasterboard, gypsum plasterboard type F, type H (where reduced water absorption rate needed)	12,5
2	Timber frame, column cross-section min. (80 × 100) mm, Sip panel at least SE SIP 120 (panel skin mad of 15 mm OSB boards), insulation core from EPS or EPS with graphite or rigid PU foam	min. 120
3	Surface board, gypsum plasterboard, gypsum plasterboard type F, type H (where reduced water absorption rate needed)	12,5
EXT	–	–

Figure 4 – Internal dividing wall 1

Dimensions in mm

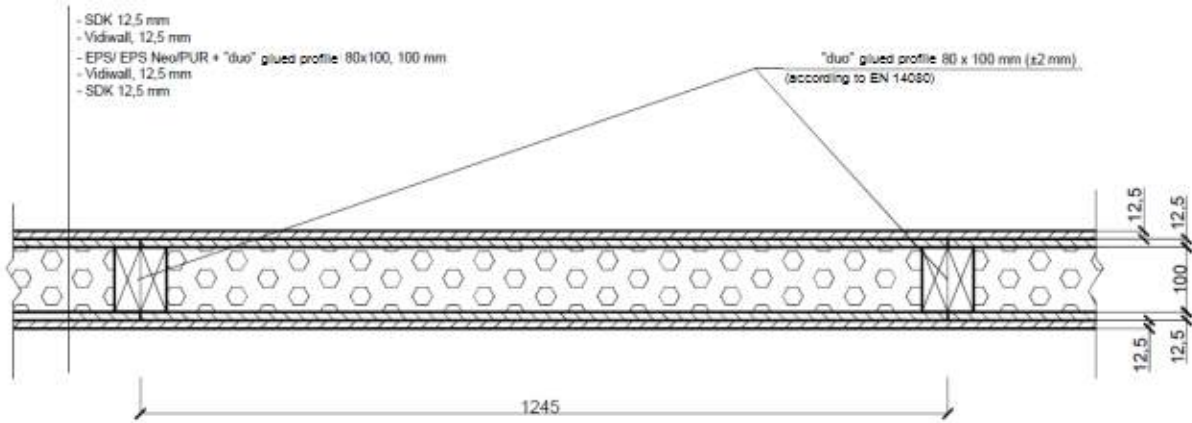

Layer	Description	Layer thickness (mm)
INT	–	–
1	Surface board, gypsum plasterboard, gypsum plasterboard type F, type H (where reduced water absorption rate needed)	12,5
2	Timber frame, column cross-section min. (80 × 100) mm, Sip panel at least SE SIP 115 (panel skin mad of 12,5 mm gypsum fibre boards "Vidiwall"), insulation core from EPS or EPS with graphite or rigid PU foam	min. 115
3	Surface board, gypsum plasterboard, gypsum plasterboard type F, type H (where reduced water absorption rate needed)	12,5
EXT	–	–

Figure 5 – Internal dividing wall 2

Dimensions in mm

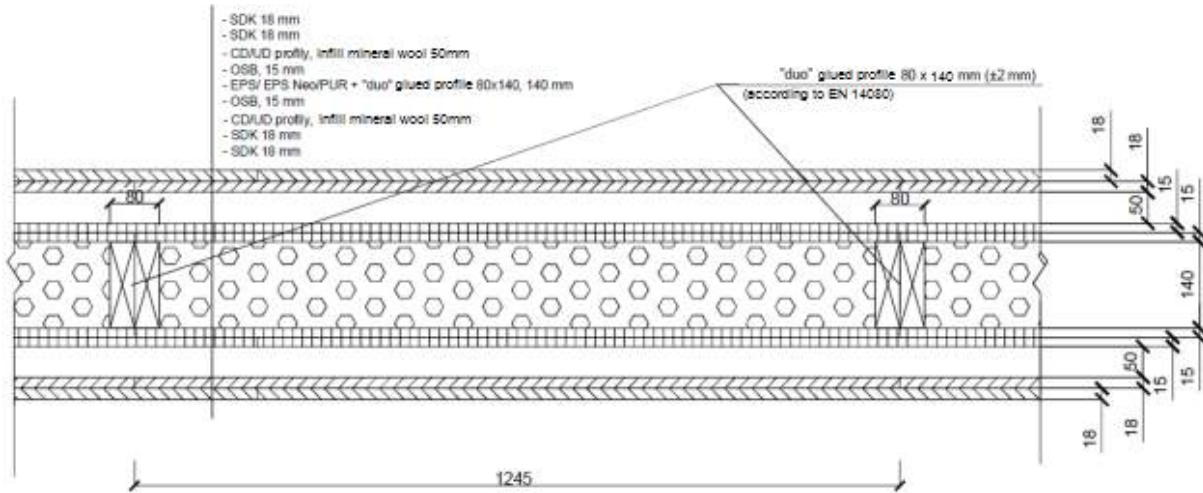

Layer	Description	Layer thickness (mm)
INT	-	-
1	Surface board, gypsum plasterboard, gypsum plasterboard type F, type H (where reduced water absorption rate needed)	18
2	Surface board, gypsum plasterboard, gypsum plasterboard type F, type H (where reduced water absorption rate needed)	18
3	CD/UD metal framing components for gypsum board systems, infill mineral wool thermal insulation (MW) for walls	50
4	OSB board	15
5	Timber frame, column cross-section min. (80 × 140) mm, Sip panel at least SE SIP 170 (panel skin mad of 15 mm OSB board), insulation core from EPS or EPS with graphite or rigid PU foam	min. 170
6	OSB board	15
7	CD/UD metal framing components for gypsum board systems, infill mineral wool thermal insulation (MW) for walls	50
8	Surface board, gypsum plasterboard, gypsum plasterboard type F, type H (where reduced water absorption rate needed)	18
9	Surface board, gypsum plasterboard, gypsum plasterboard type F, type H (where reduced water absorption rate needed)	18
EXT	-	-

Figure 6 – Internal dividing wall 3

External walls

The main part of the construction of the external walls is constituted by wood loadbearing elements and SE SIP panels. External walls are made of panels at least SE SIP 165 (skin of the panels made of 12,5 mm thick gypsum fibreboards) or SE SIP 170 (skin of the panels made of 15 mm OSB boards) or SE SIP panels with greater thickness can be used. Internal lining of the panels is from gypsum plasterboards. The external thermal insulation composite system from EPS is attached on exterior side of the SE SIP panels.

Dimensions in mm

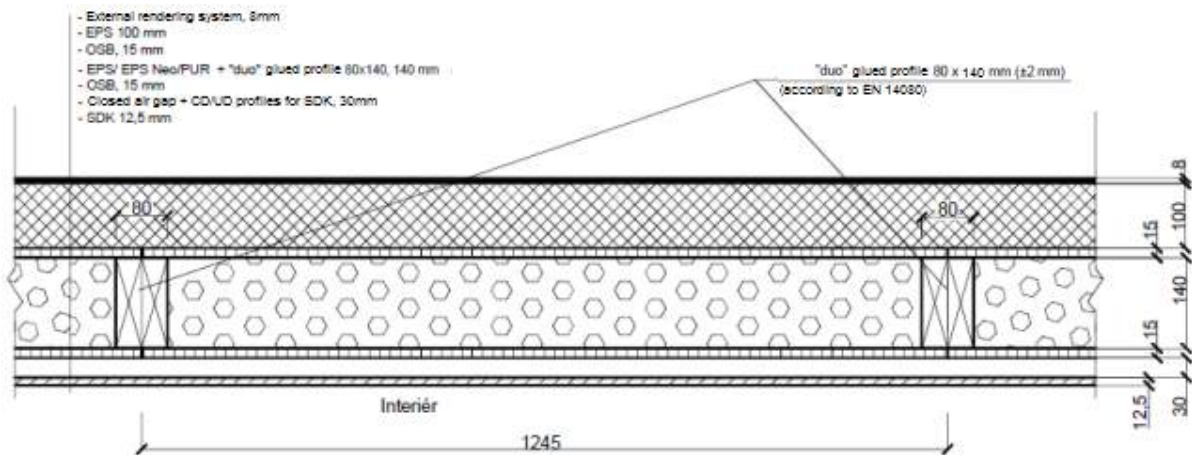

Layer	Description	Layer thickness (mm)
INT	–	–
1	Surface board, gypsum plasterboard, gypsum plasterboard type F, type H (where reduced water absorption rate needed)	12,5
2	Closed air gap CD/UD metal framing components for gypsum board systems	30
3	Timber frame, column cross-section min. (80 × 140) mm, Sip panel at least SE SIP 170 (panel skin mad of 15 mm OSB board), Insulation core from EPS or EPS with graphite or rigid PU foam	min. 170
4	External thermal insulation composite system from EPS	100
5	External rendering system	8
EXT	–	–

Figure 7 – External wall 1

Dimensions in mm

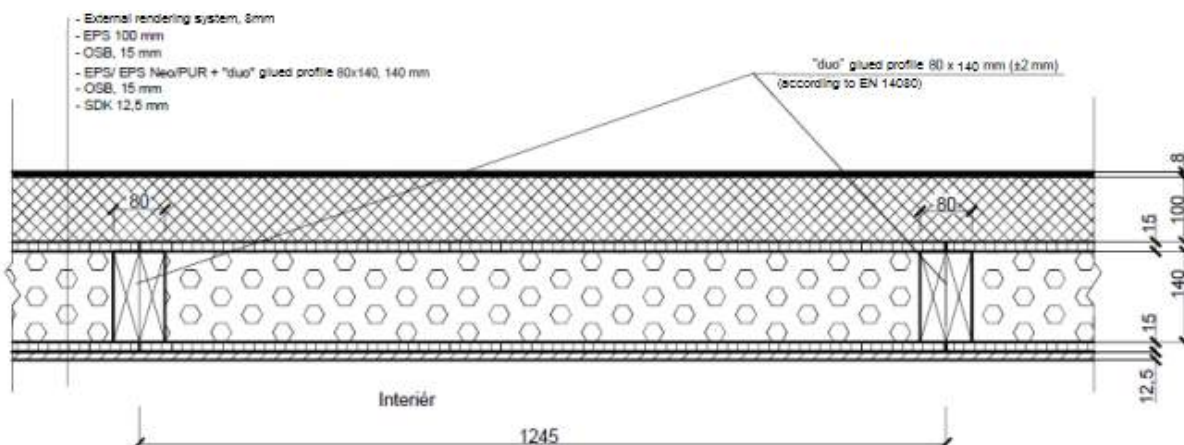

Layer	Description	Layer thickness (mm)
INT	-	-
1	Surface board, gypsum plasterboard, gypsum plasterboard type F, type H (where reduced water absorption rate needed)	12,5
2	Timber frame, column cross-section min. (80 × 140) mm, Sip panel at least SE SIP 170 (panel skin mad of 15 mm OSB board), insulation core from EPS or EPS with graphite or rigid PU foam	min. 170
3	External thermal insulation composite system from EPS	100
4	External rendering system	8
EXT	-	-

Figure 8 – External wall 2

Dimensions in mm

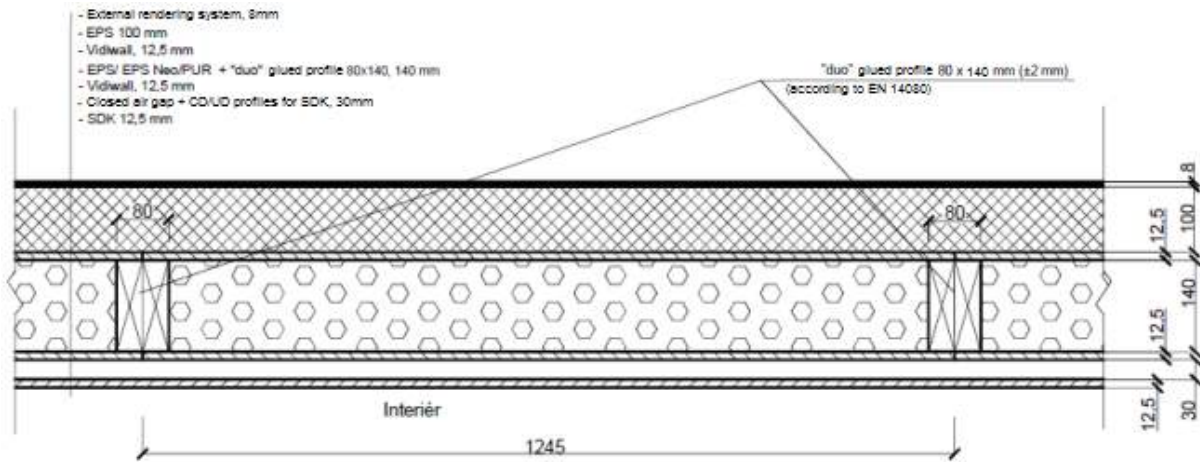

Layer	Description	Layer thickness (mm)
INT	–	–
1	Surface board, gypsum plasterboard, gypsum plasterboard type F, type H (where reduced water absorption rate needed)	12,5
2	Closed air gap CD/UD metal framing components for gypsum board systems	30
3	Timber frame, column cross-section min. (80 × 140) mm, Sip panel at least SE SIP 165 (panel skin mad of 12,5 mm gypsum fibre boards "Vidiwall"), insulation core from EPS or EPS with graphite or rigid PU foam	min. 165
4	External thermal insulation composite system from EPS	100
5	External rendering system	8
EXT	–	–

Figure 9 – External wall 3

Dimensions in mm

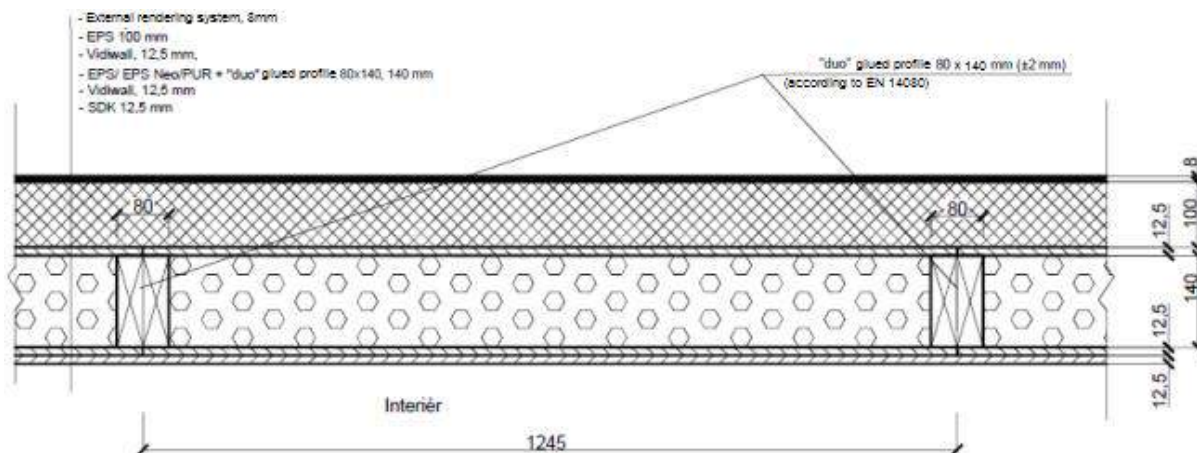

Layer	Description	Layer thickness (mm)
INT	-	-
1	Surface board, gypsum plasterboard, gypsum plasterboard type F, type H (where reduced water absorption rate needed)	12,5
2	Timber frame, column cross-section min. (80 × 140) mm, Sip panel at least SE SIP 165 (panel skin mad of 12,5 mm gypsum fibre boards "Vidiwall"), insulation core from EPS or EPS with graphite or rigid PU foam	min. 165
3	External thermal insulation composite system from EPS	100
4	External rendering system	8
EXT	-	-

Figure 10 – External wall 4

Floors

The main part of the construction of the floors is constituted by wood loadbearing elements and SE SIP panels. Floors are made of panels at least SE SIP 210 (skin of the panels made of 15 mm OSB boards) or SE SIP panels with greater thickness can be used. Only SE SIP panels with 15 mm OSB skin can be used for floors. the ceiling of the floors is made of gypsum plasterboards.

Dimensions in mm

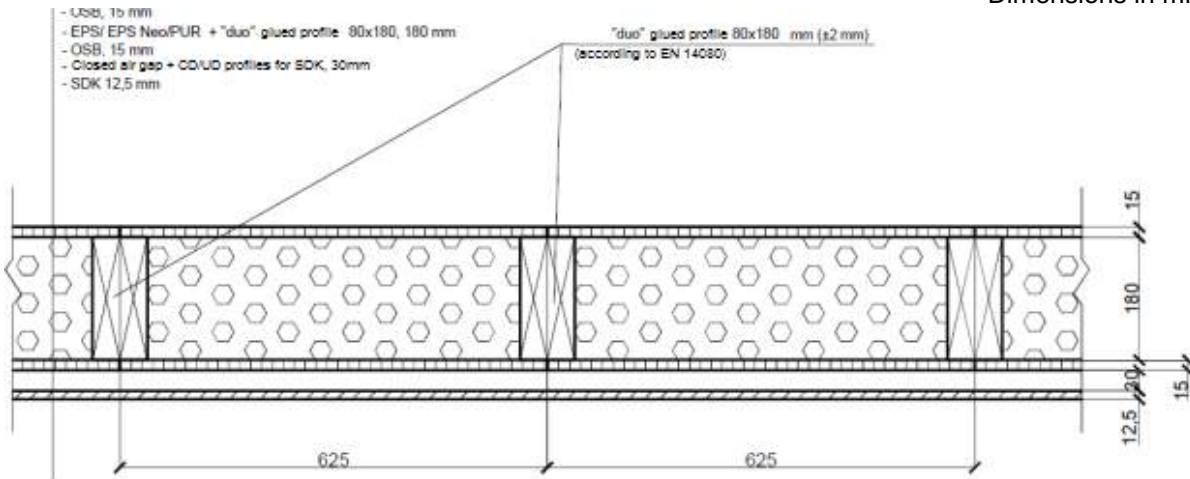

Layer	Description	Layer thickness (mm)
EXT	–	–
1	Timber beams, cross-section min. (80 × 180) mm, SIP panel at least SE SIP 210 (panel skin mad of 15 mm OSB board), Insulation core from EPS or EPS with graphite or rigid PU foam	min. 210
2	Closed air gap CD/UD metal framing components for gypsum board systems	30
3	Ceiling, gypsum plasterboard, gypsum plasterboard type F, type H (where reduced water absorption rate needed)	12,5
INT	–	–

Figure 11 – Floor 1

Dimensions in mm

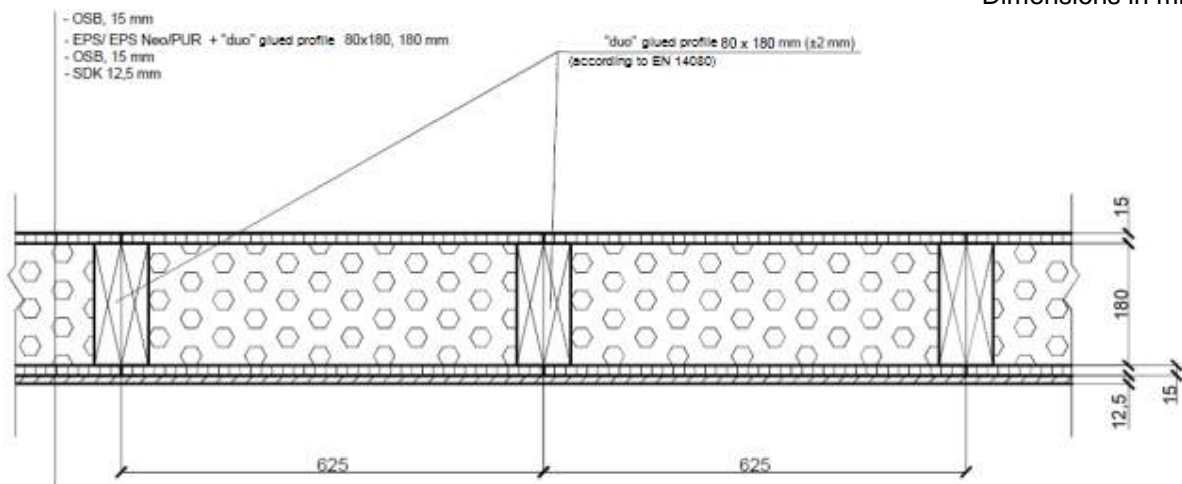

Layer	Description	Layer thickness (mm)
EXT	–	–
1	Timber beams, cross-section min. (80 × 180) mm, SIP panel at least SE SIP 210 (panel skin mad of 15 mm OSB board), Insulation core from EPS or EPS with graphite or rigid PU foam	min. 210
2	Ceiling, gypsum plasterboard, gypsum plasterboard type F, type H (where reduced water absorption rate needed)	12,5
INT	–	–

Figure 12 – Floor 2

Roof

The main part of the construction of the roof is constituted by wood loadbearing elements and SE SIP panels. Roofs are made of panels at least SE SIP 210 (skin of the panels made of 15 mm OSB boards) or SE SIP panels with greater thickness can be used. Only SE SIP panels with 15 mm OSB skin can be used for floors. Timber rafters with cross-section dimensions at least (80 × 180) mm should be used or roof beams according to individual mechanical and stability report for particular kit (Roof 2).

Dimensions in mm

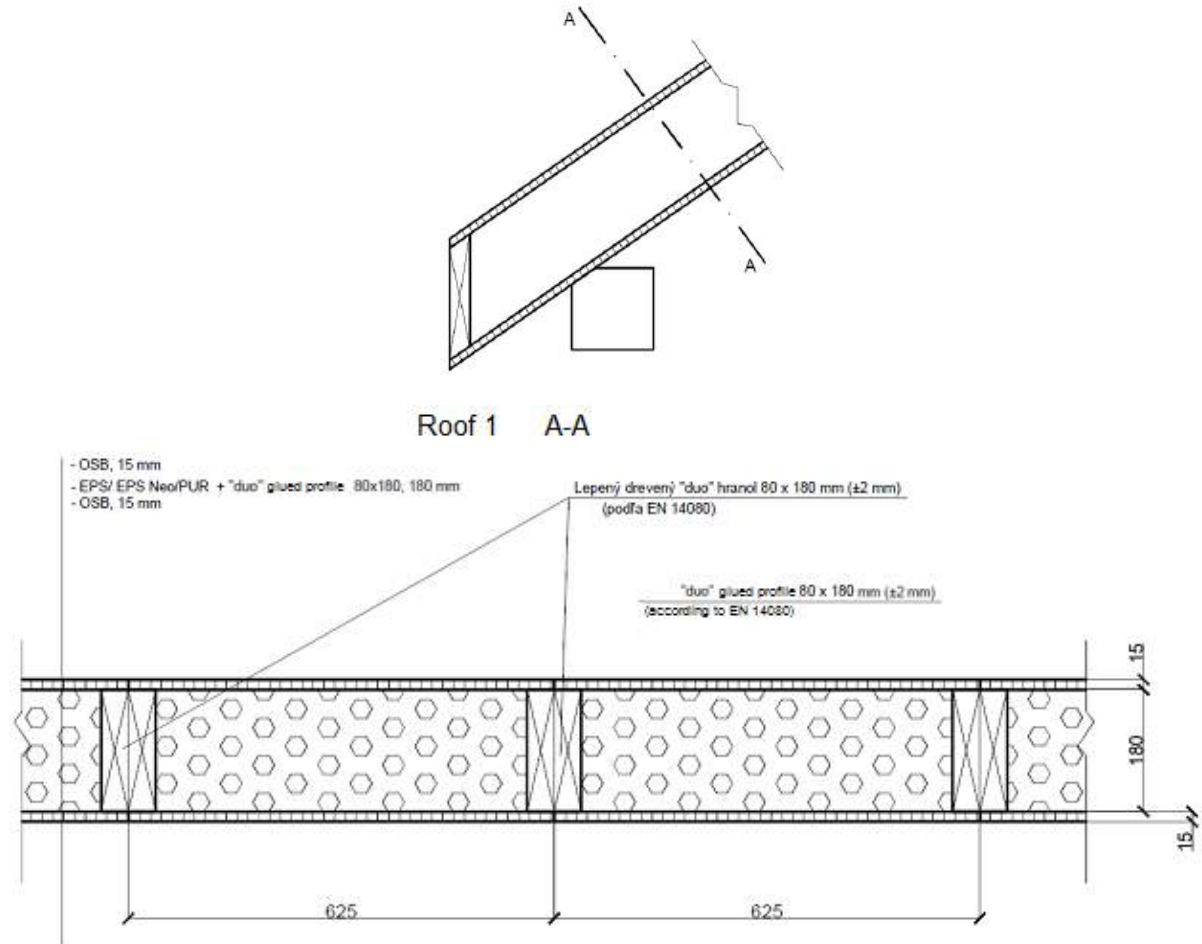

Layer	Description	Layer thickness (mm)
INT	-	-
1	Timber rafters, cross-section min. (80 × 180) mm, SIP panel at least SE SIP 210 (panel skin mad of 15 mm OSB board), Insulation core from EPS or EPS with graphite or rigid PU foam	min. 210
EXT	-	-

Figure 13 – Roof 1

Dimensions in mm

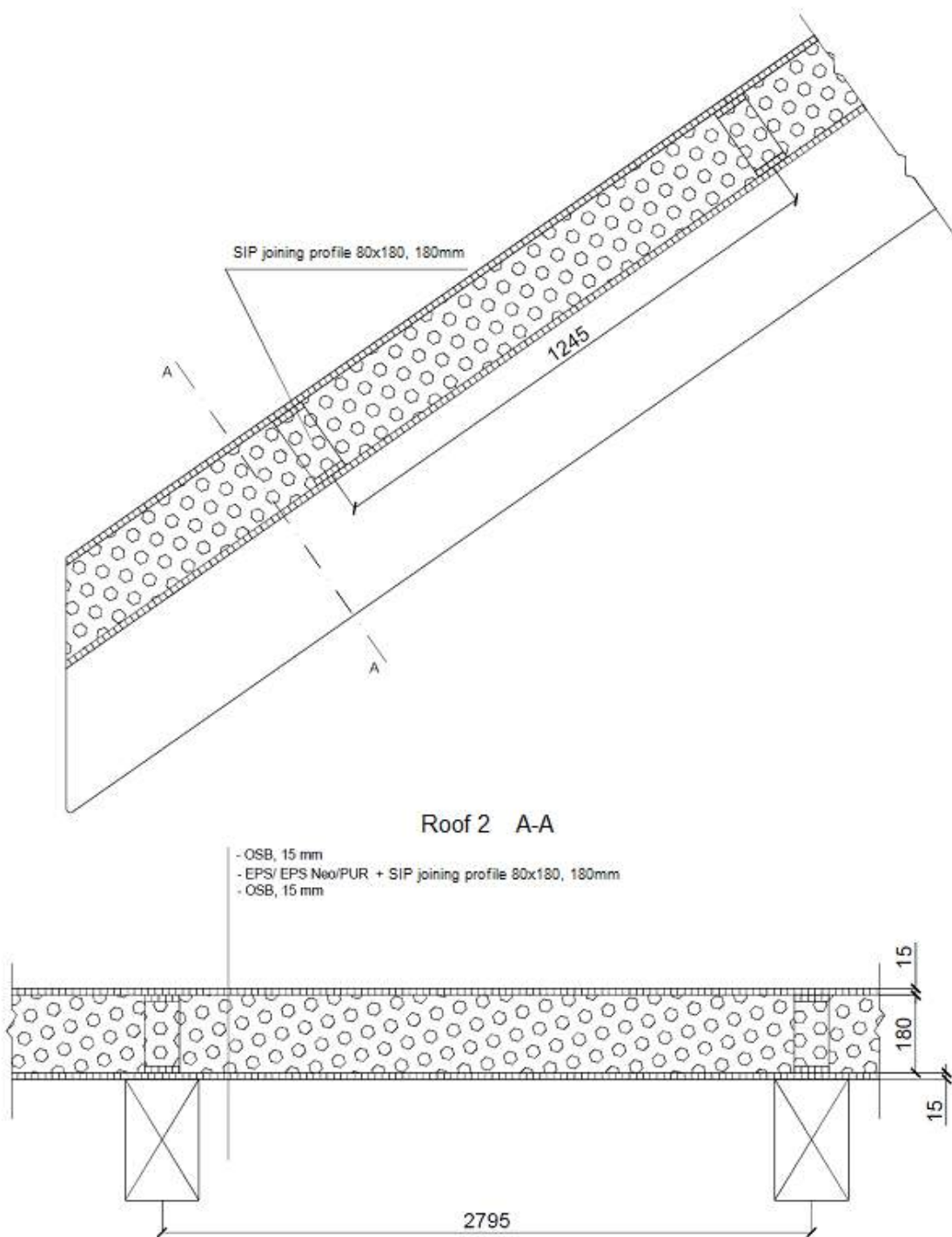

Layer	Description	Layer thickness (mm)
INT	-	-
1	SIP joining profiles min. (80 × 180) mm, SIP panel at least SE SIP 210 (panel skin made of 15 mm OSB board), Insulation core from EPS or EPS with graphite or rigid PU foam	min. 210
2	Timber or glued laminated roof beams according to individual mechanical resistance and stability report	-
EXT	-	-

Figure 14 – Roof 2

Annex 2

Materials and components specifications

Table 1 – Materials and components specifications

Component/material	Technical specification	Class	λ_D W/(m·K)	μ (-)	Reaction to fire class	
Structural timber with rectangular cross section	STN 49 1531 EN 14081-1 EN 338	C 24, C 30	0,130	50	D-s2, d0	Commission Decision 2003/43/EC ¹⁾
Structural finger jointed solid timber	EN 15497 EN 338	C 24, C 30	0,130	50	D-s2, d0	Commission Decision 2003/43/EC ¹⁾
Glued laminated timber and glued solid timber	EN 14080	min. GL 24h or min. GL 24c	0,130	50	D-s2, d0	Commission Decision 2003/43/EC ¹⁾
Metal framing components for gypsum board systems	EN 14195	According to manufacturer specification	–	–	A1	Commission Decision 96/603/EC ²⁾
Screws for wood	According to manufacturer specification	–	–	–	–	NPD
Nails		–	–	–	–	NPD
Other steel mechanical fasteners		–	–	–	–	NPD
External rendering system	According to manufacturer specification	–	–	–	–	NPD
One composite polyurethane glue	According to manufacturer specification	Polychem systems DEKO D4	–	–	–	NPD
Gypsum fibreboard for loadbearing constructions	ETA-07/0067	Vidiwall	0,300	21	A2-s0, d2	STN EN 13501-1+A1
Gypsum plasterboard	EN 520	type DF type DFRIEH2 type DFRH2	0,21	10	A2-s0, d2	Commission Decision 2003/43/EC ¹⁾
OSB board	EN 13986	OSB/3, OSB/4	0,130	200	D-s2, d0	EN 13501-1+A1
Expanded polystyrene thermal insulation (EPS)	EN 13163	min. CS(10)70, min. TR 100	0,041 (0,039) ³⁾	50	E	STN EN 13501-1+A1
Mineral wool thermal insulation (MW)	EN 13162	For use in dividing walls	According to manufacturer specification		A1	STN EN 13501-1+A1
Expanded polystyrene thermal insulation (EPS) with graphite	EN 13163	min. CS(10)70, min. TR 100	0,033 (0,031) ³⁾	50	E	STN EN 13501-1+A1
Thermal insulation from rigid polyurethane foam	EN 13165	According to manufacturer specification	0,030 (0,028) ³⁾	260	E	STN EN 13501-1+A1
Flexible sheets for waterproofing	EN 13859-1	According to manufacturer specification			–	NPD ⁴⁾

¹⁾ Amended by Commission Decisions 2003/593/EC, 2006/673/EC and 2007/348/EC.
²⁾ Amended by Commission Decisions 2000/605/EC and 2003/424/EC.
³⁾ λ_D – declared value of coefficient of thermal conductivity.
⁴⁾ No performance determined

Annex 3

Mechanical resistance of the constructions

The mechanical resistance is given for the panels with undivided OSB/3 skin and EPS core. The skin must be area-wide glued to the core by appropriate glue for structural use in at least use class 2 or higher. The core and skin of the core from OSB boards or gypsum fibre boards for structural use are given in Annex 1.

Walls

The mechanical resistance of the walls is given for constructions without openings. Acting loads are given in Figure 15.

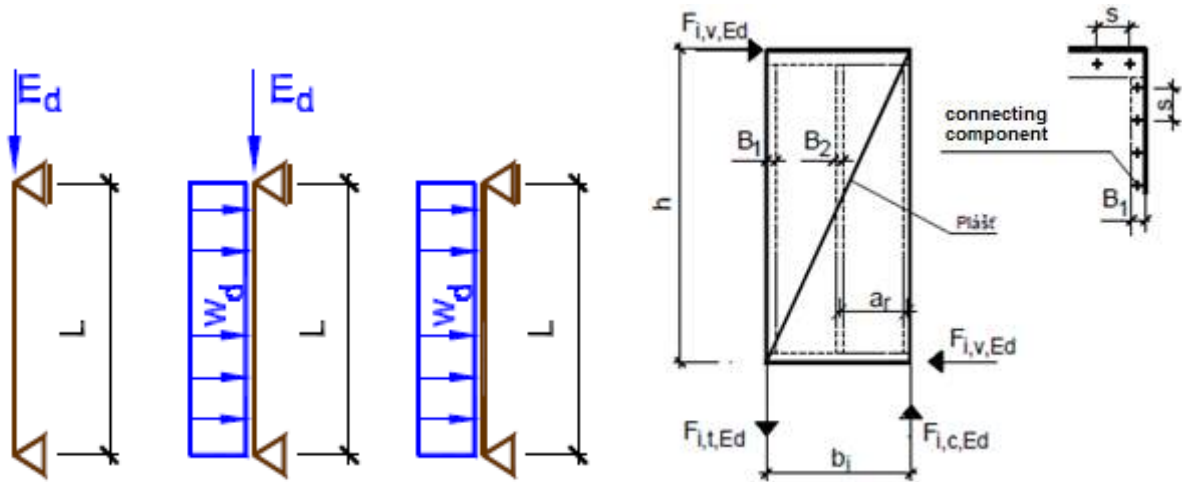

Figure 15 – Acting loads of perimeter walls

Table 2 – Mechanical resistance of the wall constructions

Wall construction	Loads – design values				
	Medium term in vertical direction E_d (kN/m)	Combination of loads		Short term perpendicular to wall w_d (kN/m ²)	Short term, Racking resistance $F_{v,Ed}$ (kN)
		Medium term in vertical direction E_d (kN/m)	Short term perpendicular to wall w_d (kN/m ²)		
External wall 1	190,379	150,218	3,000	4,500	2,490
External wall 2					
External wall 3					
External wall 4					
Internal dividing wall 1	207,041	–	–	–	
Internal dividing wall 3					
Internal dividing wall 2	78,010	–	–	–	
NOTE 1	Given values re valid for wall height $h = 2\,795$ mm.				
NOTE 2	Values for short term racking resistance is given as load-bearing capacity of the one racking wall with length $b_1 = 1\,254$ mm. Wall has to be anchored to substructure according to Figure 16.				
NOTE 3	Load-bearing capacities are determined for use class 1 in case of internal dividing walls. Load-bearing capacities are determined for use class 2 in case of external walls.				

Dimensions in mm

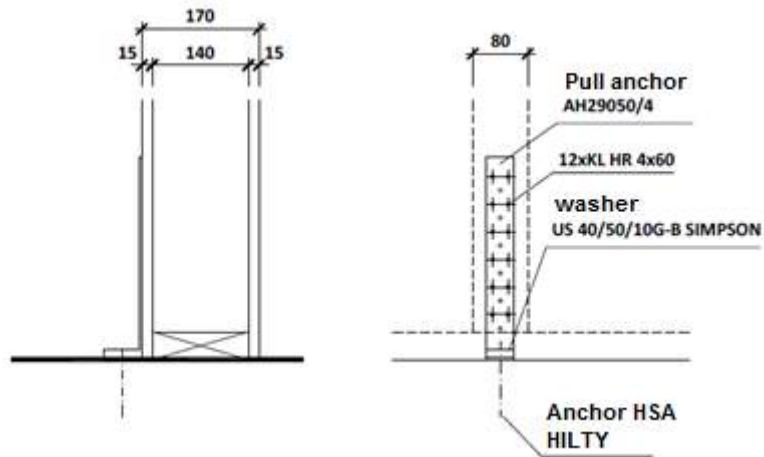

Figure 16 – Example of anchoring to ensure required racking resistance of wall plain direction

Floors

The mechanical resistance according to Table 3 is given for constructions without openings. Acting loads for each alternative are given in Figures 17, 18, 19, 20 and 21.

Dimensions in mm

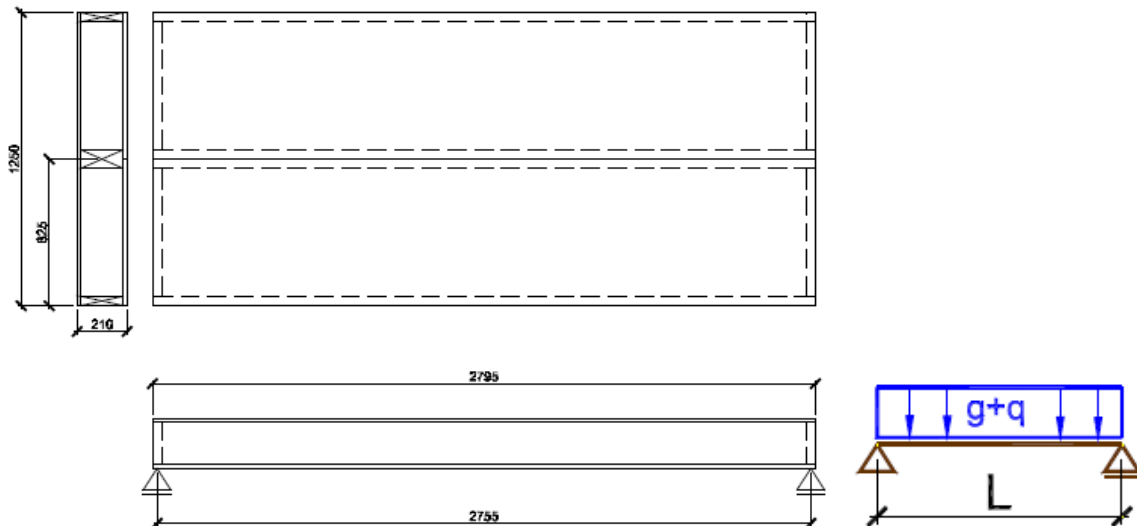

Figure 17 – Individual floor panel with segment width 625 mm

Dimensions in mm

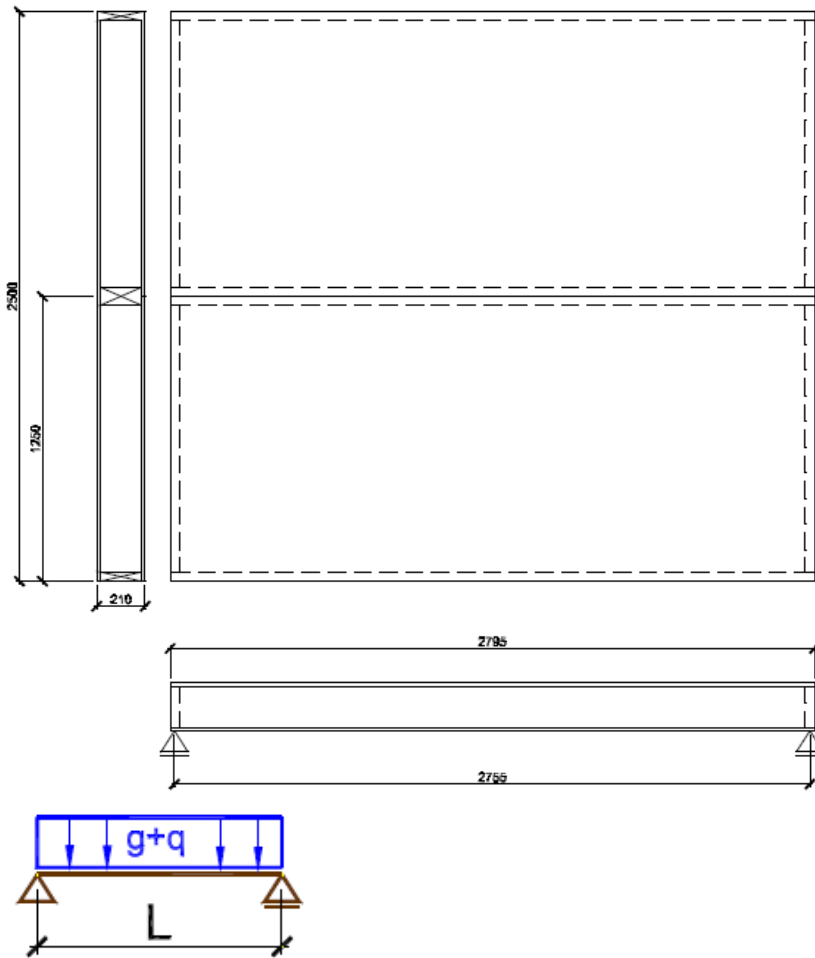

Figure 18 – Individual floor panel with segment width 1 245 mm

Dimensions in mm

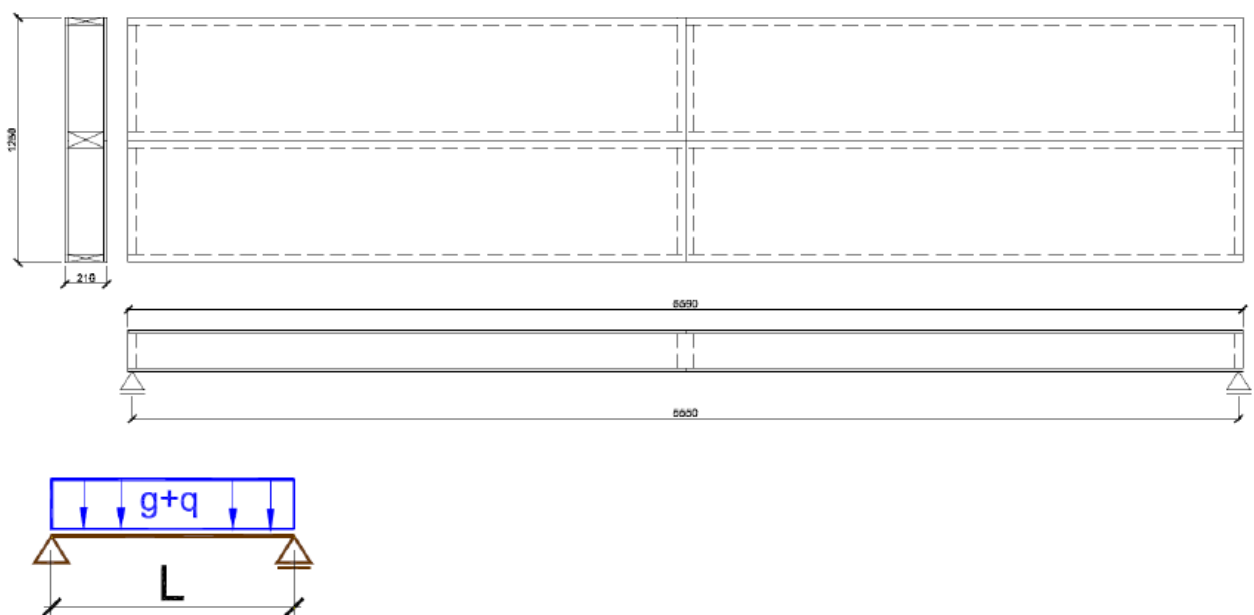

Figure 19 – Set of floor panel with segment width 625 mm

Dimensions in mm

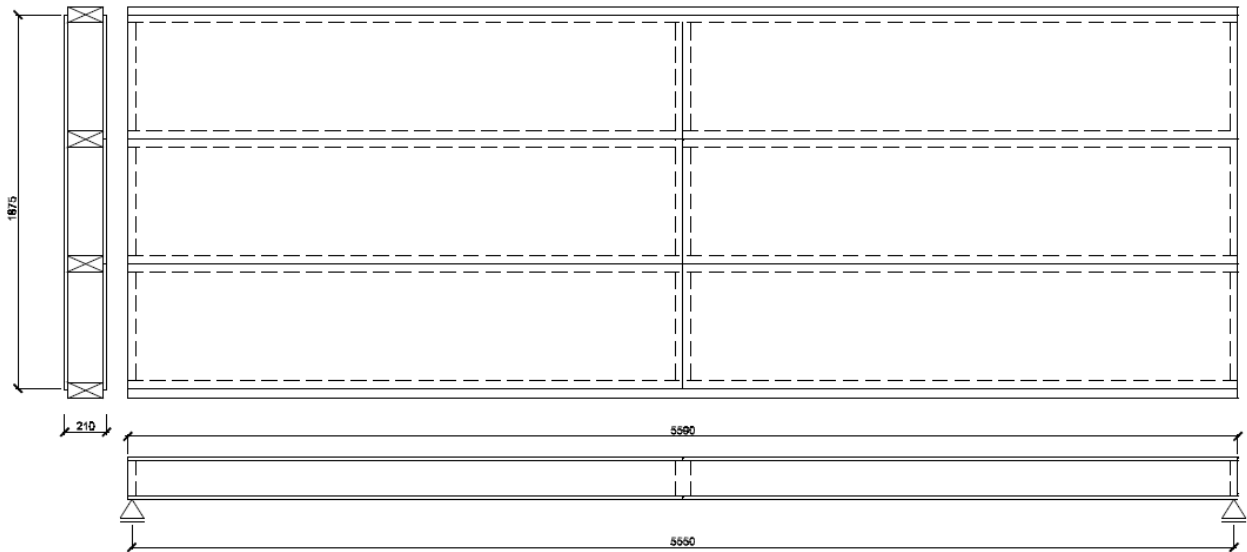

Figure 20 – Racking resistance in floor and roof plain, alternative 1

Dimensions in mm

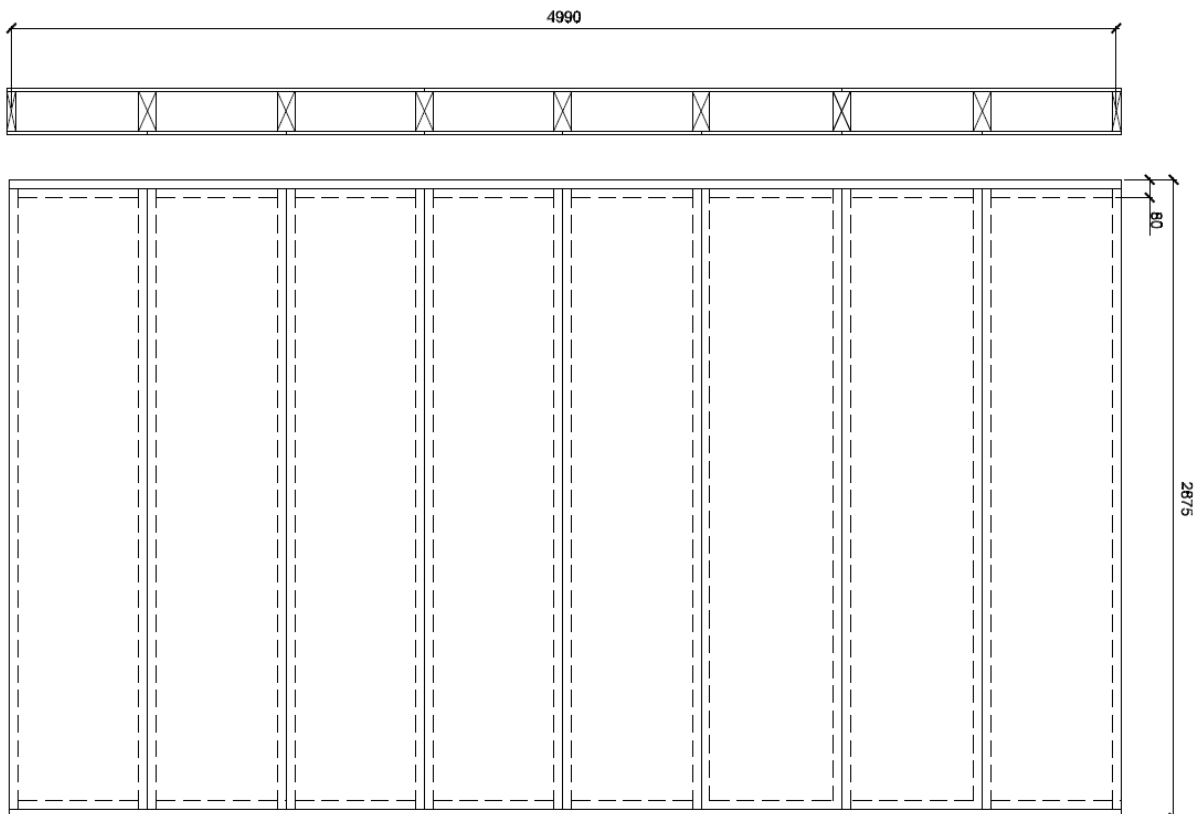

Figure 21 – Racking resistance in floor and roof plain, alternative 2

Table 3 – Mechanical resistance of the floors

Construction	Medium term load in vertical direction		Racking resistance in floor plain		
	E_d (kN/m ²)	Loading scheme and acting loads	E_d (kN/m)	Loading scheme and acting loads	
Floor 1	9,715	Individual floor panel with segment width 625 mm	4,800	Alternative 1 – wind loads acting perpendicular to longitudinal ribs	
Floor 2					
Floor 1	4,567	Individual floor panel with segment width 1 245 mm		–	Alternative 2 – wind loads acting in longitudinal direction of the ribs
Floor 2					
Floor 1	1,987	Set of floor panel with segment width 625 mm	–		–
Floor 2					

NOTE Longitudinal ribs of the floor sets must be made in one (not divided) trough whole length of the floor span.

Roofs

The mechanical resistance according to Table 4 is given for constructions without openings. Acting loads for each alternative are given in Figures 22 and 23.

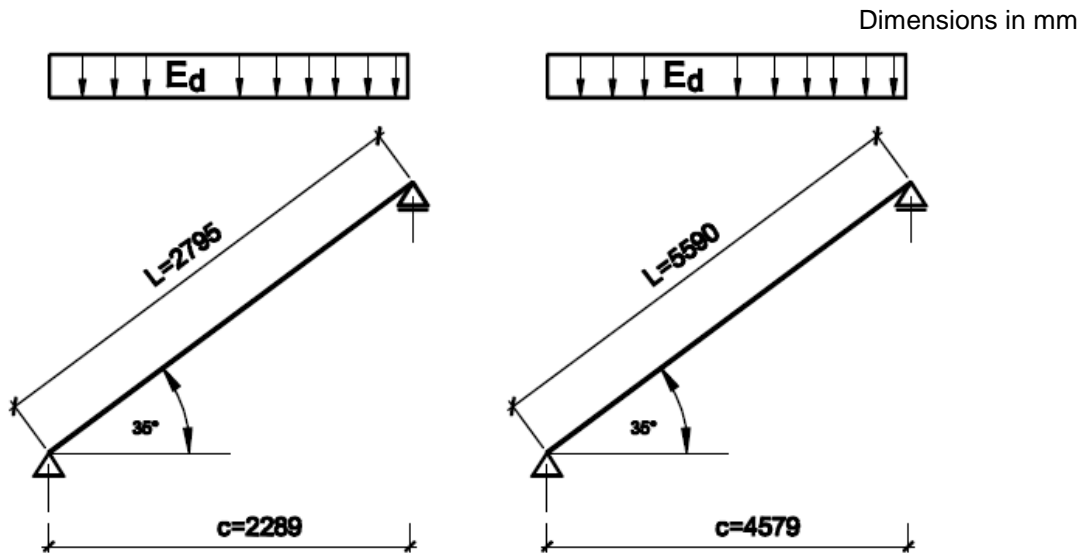

Figure 22 – Loading scheme for roof 1, for panel length $L = 2\,795$ mm and set of panels with length $L = 5\,590$ mm

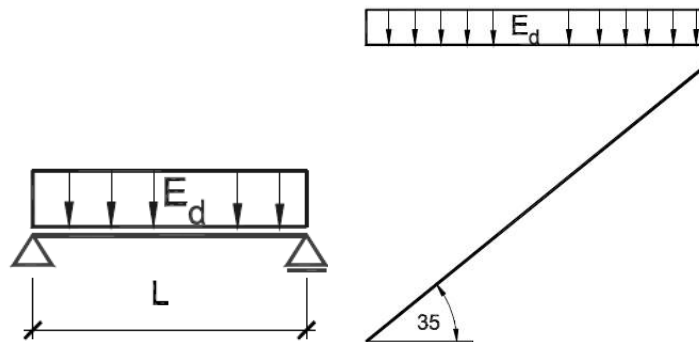

Figure 23 – Loading scheme for roof 2

Table 4 – Mechanical resistance of the roofs, roof pitch 35°

Construction	Medium term load in vertical direction		Racking resistance in floor plain	
	E_d (kN/m ²)	Loading scheme and acting loads	E_d (kN/m)	Loading scheme and acting loads
Roof 1	14,730	Panel length $L = 2\,795$ mm	2,550	Alternative 1 – wind loads acting perpendicular to longitudinal ribs, Figure 20
Roof 1	3,920	Set of panels with length $L = 5\,590$ mm		Alternative 2 – wind loads acting in longitudinal direction of the ribs, Figure 21
Roof 2	5,730	Axial distance of the supports $L = 2\,795$ mm	–	–

Annex 4

Fire resistance of the constructions

Table 5 – Fire resistance of the external wall constructions in case of fire from inside to outside

Construction	Panel type	Fire resistance	Note
External wall 1	SE SIP 170	REW/REI 30	Internal lining made of at least 12,5 mm thick gypsum plasterboard type F
	SE SIP 210	REW/REI 45	Internal lining made of at least 18 mm thick gypsum plasterboard type F
	SE SIP 270	REW/REI 60	Internal lining made of at least two 15 mm thick gypsum plasterboards type F (min. 30 mm together), slits of the boards must be covered in both gypsum plasterboard layer plains
External wall 2	SE SIP 170	REW/REI 30	Internal lining made of at least 12,5 mm thick gypsum plasterboard type F
	SE SIP 210	REW/REI 45	Internal lining made of at least 18 mm thick gypsum plasterboard type F
	SE SIP 270	REW/REI 60	Internal lining made of at least two 15 mm thick gypsum plasterboards type F (min. 30 mm together), slits of the boards must be covered in both gypsum plasterboard layer plains
External wall 3	SE SIP 165	REW/REI 45	Internal lining made of at least 12,5 mm thick gypsum plasterboard type F
	SE SIP 205		Thickness of the „Vidiwall“ board on interior side of the „SE SIP“ panel at least 15 mm
	SE SIP 265	REW/REI 60	Internal lining made of at least 18 mm thick gypsum plasterboard type F Thickness of the „Vidiwall“ board on interior side of the „SE SIP“ panel at least 15 mm
External wall 4	SE SIP 165	REW/REI 45	Internal lining made of at least 12,5 mm thick gypsum plasterboard type F Thickness of the „Vidiwall“ board on interior side of the „SE SIP“ panel at least 15 mm
	SE SIP 205	REW/REI 60	Internal lining made of at least 18 mm thick gypsum plasterboard type F or internal lining made of at least two 12,5 mm thick gypsum plasterboards type F (min. 25 mm together), slits of the boards must be covered in both gypsum plasterboard layer plains
	SE SIP 265		Thickness of the „Vidiwall“ board on interior side of the „SE SIP“ panel at least 15 mm

Table 6 – Fire resistance of the internal dividing wall constructions

Construction	Panel type	Fire resistance	Note
Internal dividing wall1	SE SIP 130 SE SIP 170 SE SIP 210 SE SIP 270	REW/REI 30	Lining made of at least 12,5 mm thick gypsum plasterboard type F
		REW/REI 45	Lining made of at least 18 mm thick gypsum plasterboard type F
		REW/REI 60	Lining made of at least two 18 mm thick gypsum plasterboards type F (min. 36 mm together), slits of the boards must be covered in both gypsum plasterboard layer plains
Internal dividing wall2	SE SIP 125 SE SIP 165 SE SIP 205 SE SIP 265	REW/REI 30	Lining made of at least 12,5 mm thick gypsum plasterboard type F
		REW/REI 45	Lining made of at least 12,5 mm thick gypsum plasterboard type F, the thickness of the „Vidiwall skin of the SE SIP panel at least 15 mm
		REW/REI 60	Lining made of at least two 18 mm thick gypsum plasterboards type F (min. 36 mm together), slits of the boards must be covered in both gypsum plasterboard layer plains
Internal dividing wall3	SE SIP 170 SE SIP 210 SE SIP 270	REW/REI 90	Construction according to Table 9

Table 7 – Fire resistance of the roof constructions in case of fire from inside to outside

Construction	Panel type	Fire resistance	Note
Roof 1	SE SIP 210	REW/REI 15	Thickness of the OSB skin of the SE SIP panel at least 22 mm or skin made of two 15 mm thick OSB boards (min. 30 mm together)
		REW/REI 30	Construction must contain additional internal lining made of at least 12,5 mm thick gypsum plasterboard type F
	SE SIP 270	REW/REI 45	The OSB skin of the SE SIP panel must be made of two 15 mm thick OSB boards (min. 30 mm together) and construction must contain additional internal lining made of at least 18 mm thick gypsum plasterboard type F
Roof 2	SE SIP 210	REW/REI 15	Thickness of the OSB skin of the SE SIP panel at least 22 mm or skin made of two 15 mm thick OSB boards (min. 30 mm together)
		REW/REI 30	Construction must contain additional internal lining made of at least 12,5 mm thick gypsum plasterboard type F
	SE SIP 270	REW/REI 45	The OSB skin of the SE SIP panel must be made of two 15 mm thick OSB boards (min. 30 mm together) and construction must contain additional internal lining made of at least 18 mm thick gypsum plasterboard type F

Annex 5

Thermo-technical parameters of the constructions

Table 8 – Thermal transmittance of the external walls

Construction	Panel type	Insulation core of the „SE SIP“	Heat transfer resistance R_T ($m^2 \cdot K/W$)	Thermal transmittance U ($W/(m^2 \cdot K)$)	Construction thickness (mm)
External wall 1	SE SIP 170	EPS	6,06	0,165	321
		EPS with graphite	6,67	0,150	
		Rigid PU foam	6,94	0,144	
	SE SIP 210	EPS	6,90	0,145	361
		EPS with graphite	7,63	0,131	
		Rigid PU foam	8,00	0,125	
	SE SIP 270	EPS	8,13	0,123	421
		EPS with graphite	9,43	0,106	
		Rigid PU foam	9,62	0,104	
External wall 2	SE SIP 170	EPS	5,88	0,170	291
		EPS with graphite	6,49	0,154	
		Rigid PU foam	6,76	0,148	
	SE SIP 210	EPS	6,71	0,149	331
		EPS with graphite	7,46	0,134	
		Rigid PU foam	7,81	0,128	
	SE SIP 270	EPS	7,94	0,126	391
		EPS with graphite	8,93	0,112	
		Rigid PU foam	9,43	0,106	
External wall 3	SE SIP 165	EPS	5,92	0,169	316
		EPS with graphite	6,49	0,154	
		Rigid PU foam	6,80	0,147	
	SE SIP 205	EPS	6,76	0,148	356
		EPS with graphite	7,52	0,133	
		Rigid PU foam	7,87	0,127	
	SE SIP 265	EPS	7,75	0,129	416
		EPS with graphite	9,01	0,111	
		Rigid PU foam	9,43	0,106	
External wall 4	SE SIP 165	EPS	5,71	0,175	286
		EPS with graphite	6,33	0,158	
		Rigid PU foam	6,62	0,151	
	SE SIP 205	EPS	6,58	0,152	326
		EPS with graphite	7,30	0,137	
		Rigid PU foam	7,69	0,130	
	SE SIP 265	EPS	7,81	0,128	386
		EPS with graphite	8,77	0,114	
		Rigid PU foam	9,26	0,108	

NOTE Given U values includes impact of non-homogenous layers in constructions, $R_{si} = 0,13$ and $R_{e} = 0,04$ were used in calculation.

Table 9 – Thermal transmittance of the roof constructions

Construction	Panel type	Insulation core of the „SE SIP“	Heat transfer resistance R_T ($m^2 \cdot K/W$)	Thermal transmittance U ($W/(m^2 \cdot K)$)	Construction thickness (mm)
Roof 1	SE SIP 210	EPS	3,52	0,284	210
		EPS with graphite	3,98	0,251	
		Rigid PU foam	4,18	0,239	
	SE SIP 270	EPS	4,55	0,220	270
		EPS with graphite	5,15	0,194	
		Rigid PU foam	5,41	0,185	
Roof 2	SE SIP 210	EPS	4,69	0,213	210
		EPS with graphite	5,71	0,175	
		Rigid PU foam	6,25	0,160	
	SE SIP 270	EPS	6,21	0,161	270
		EPS with graphite	7,63	0,131	
		Rigid PU foam	8,40	0,119	

NOTE Given U values includes impact of non-homogenous layers in constructions, $R_{si} = 0,10$ and $R_{e} = 0,04$ were used in calculation.

Annex 6

Natural durability of wood and use classes of components and fasteners

Table 10 – Use classes according to EN 335

Type of component	Use class
Load-bearing structure external wall – external surface	3.1 (exterior occasionally wet)
Load-bearing structure internal wall Load-bearing structure external wall – internal surface, floor, roof Internal cladding	1
Internal cladding of roof, rear ventilated or as direct covering of thermal insulation	2
External components exposed to direct weathering	3.1 (exterior occasionally wet)

Table 11 – Service class according to EN 1995-1-1 of fasteners used in load-bearing constructions of the kits

Type of component	Use class
Wall, floor, roof fixing on the inside of the thermal insulation	1
Wall, floor, roof fixing on the outside of the thermal insulation, but not exposed to direct weathering	2
Wall, floor, roof fixing in exterior exposed to direct weathering	3

Table 12 – Natural durability of the wood according to EN 350

Species	Fungi	Hylotrupes	Anobium	Termites
Spruce (<i>Picea abies</i>)	4	S	S	S
Fir (<i>Abies alba</i>)	4	S	S	S
Pine (<i>Pinus sylvestris</i>)	3-4	D	D	S
Larch (<i>Larix decidua</i>)	3-4	D	D	S

Annex 7

Construction details of the kits

Dimensions in mm

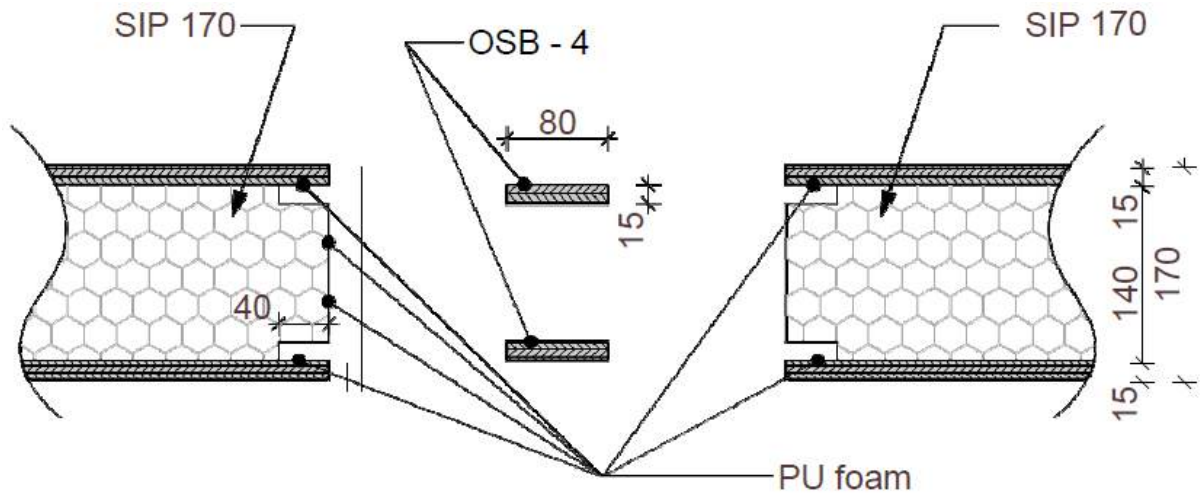

Figure 24 – Joining of the panels by spline

Dimensions in mm

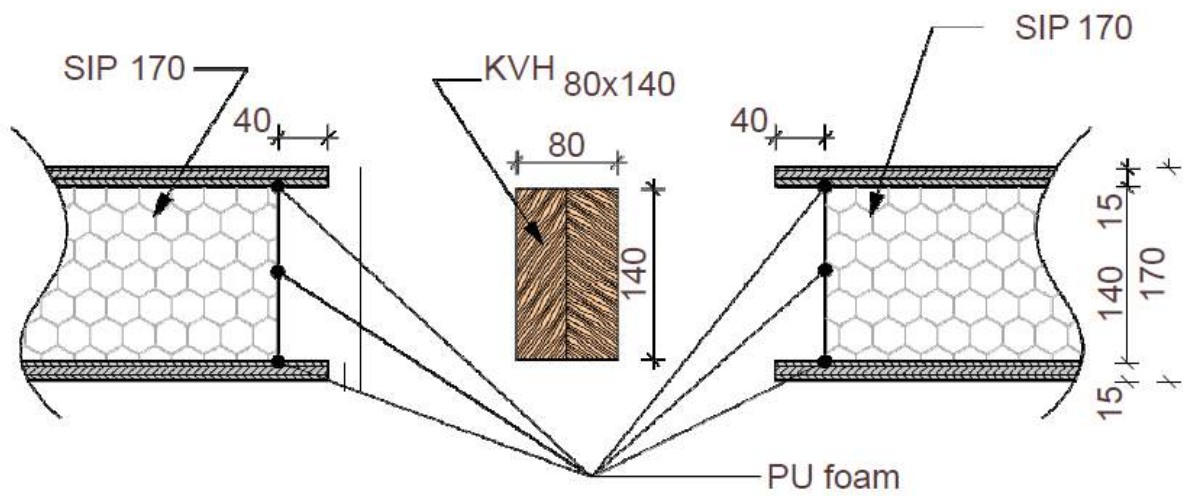

Figure 25 – Joining of the panels by wood components

Dimensions in mm

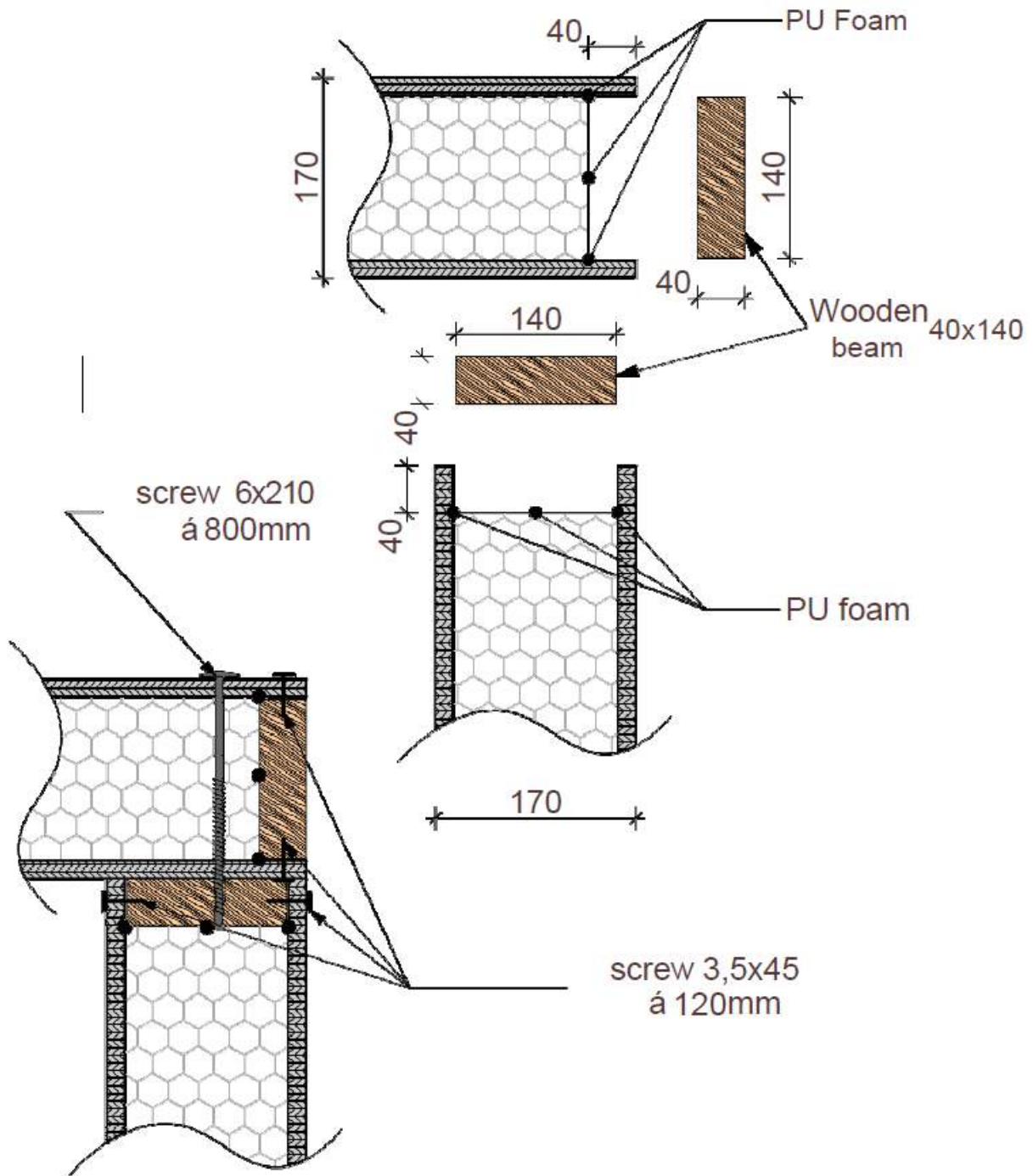

Figure 26 – Corner joint of the panels

Dimensions in mm

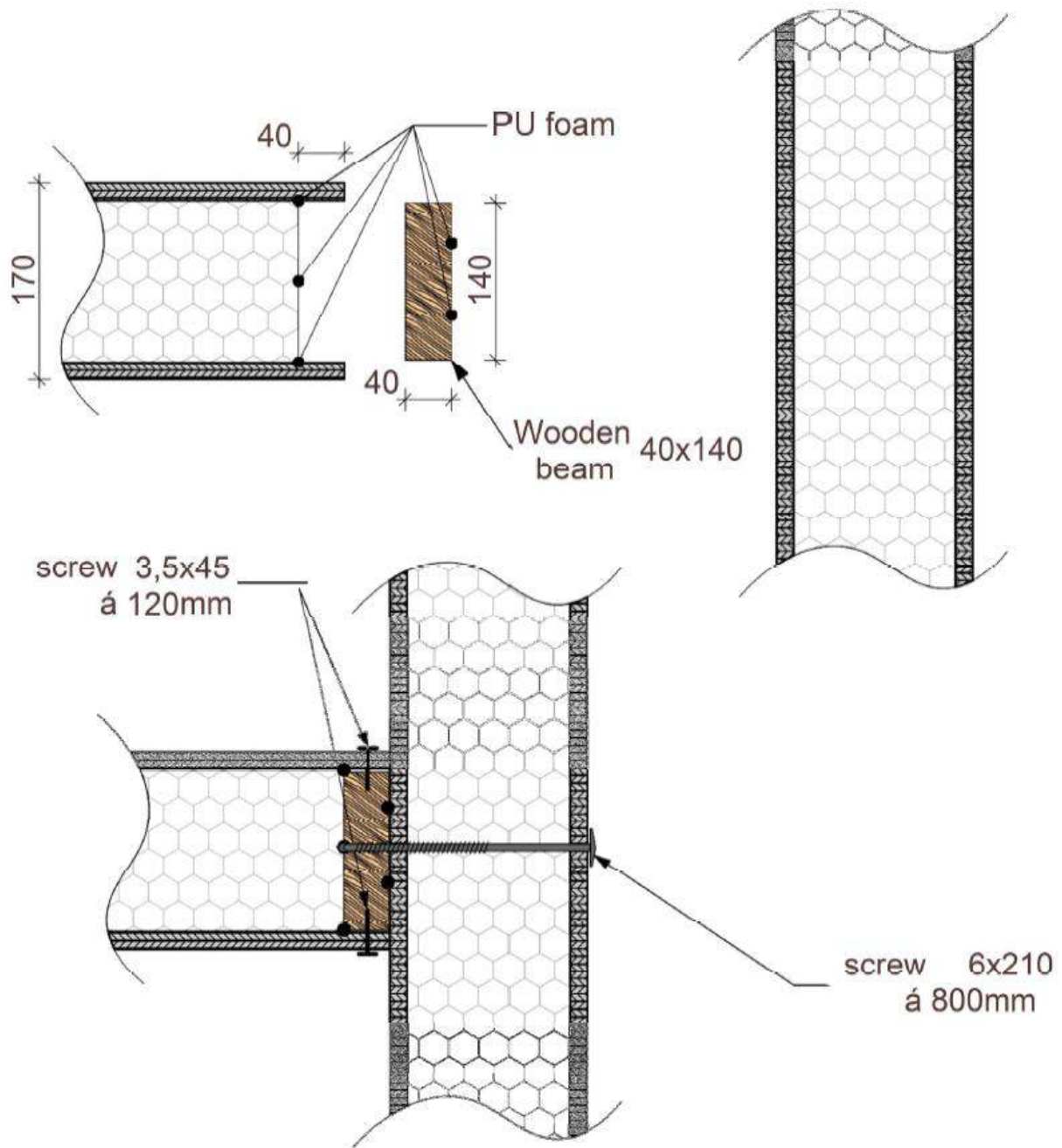

Figure 27 – Joint of the transverse panels

Dimensions in mm

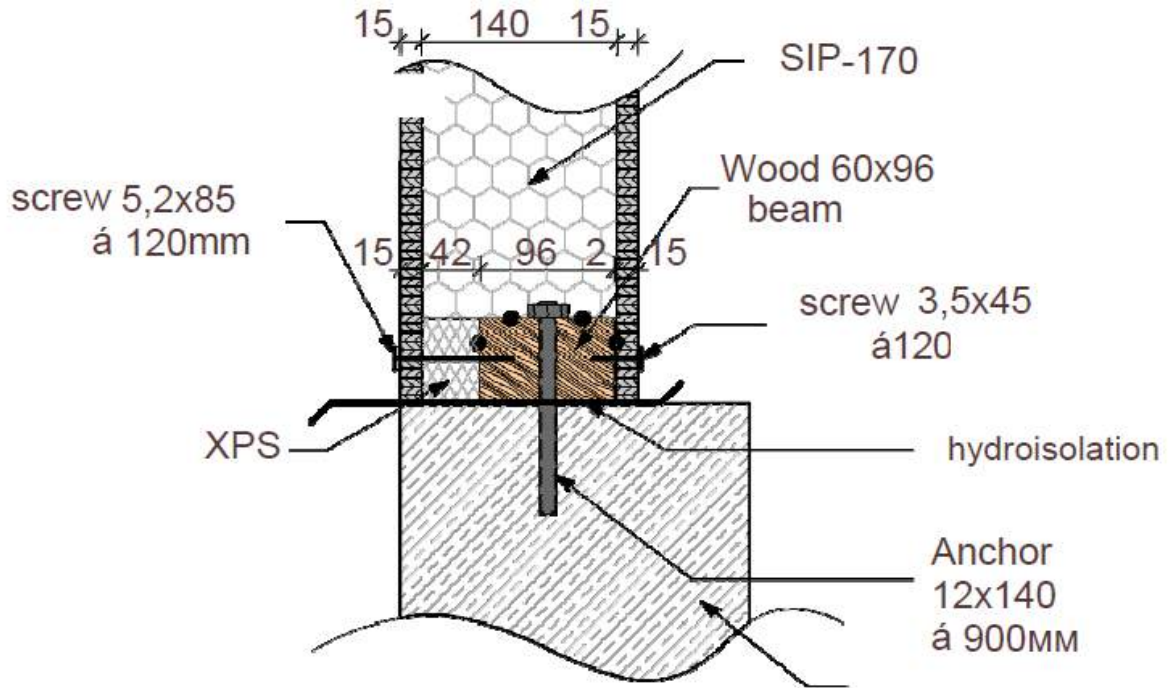

Figure 28 – Anchoring of the panel to substructure

Dimensions in mm

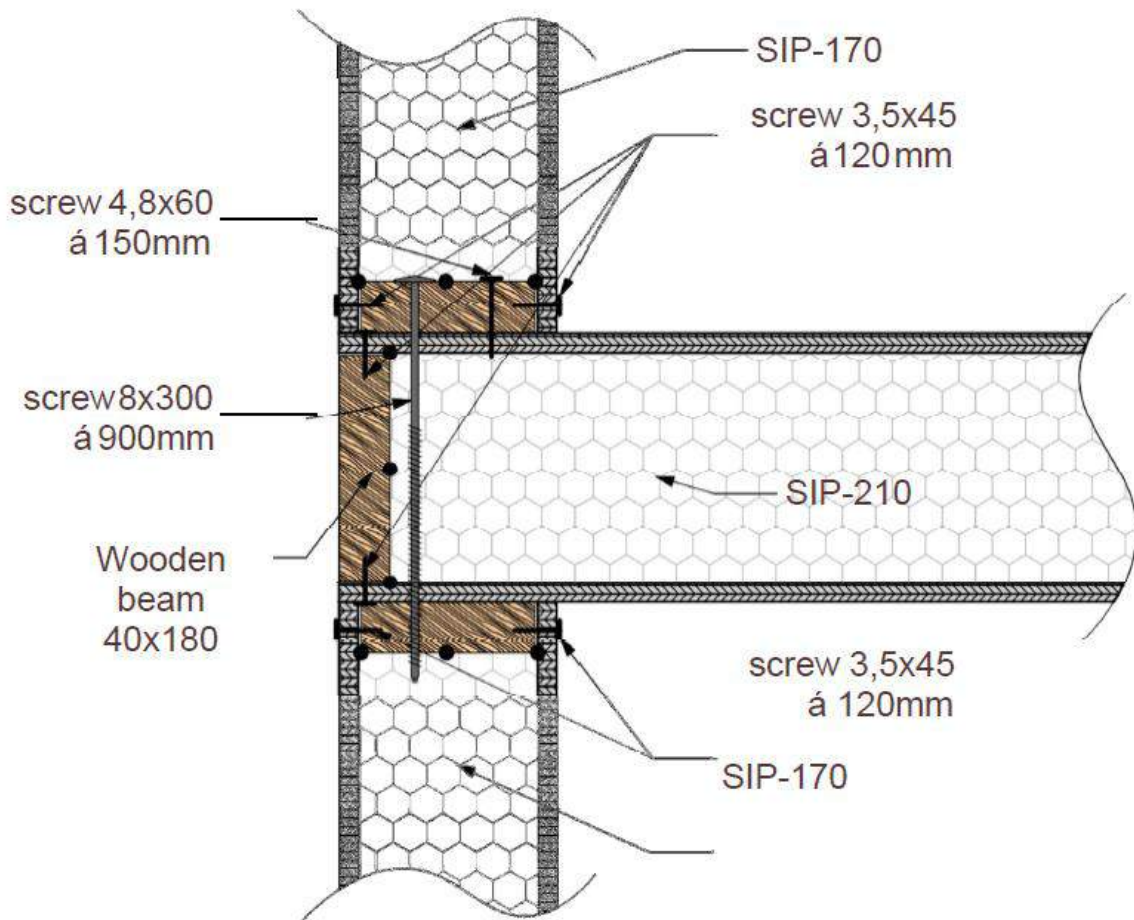

Figure 29 – Joint of the floor to wall panel

Dimensions in mm

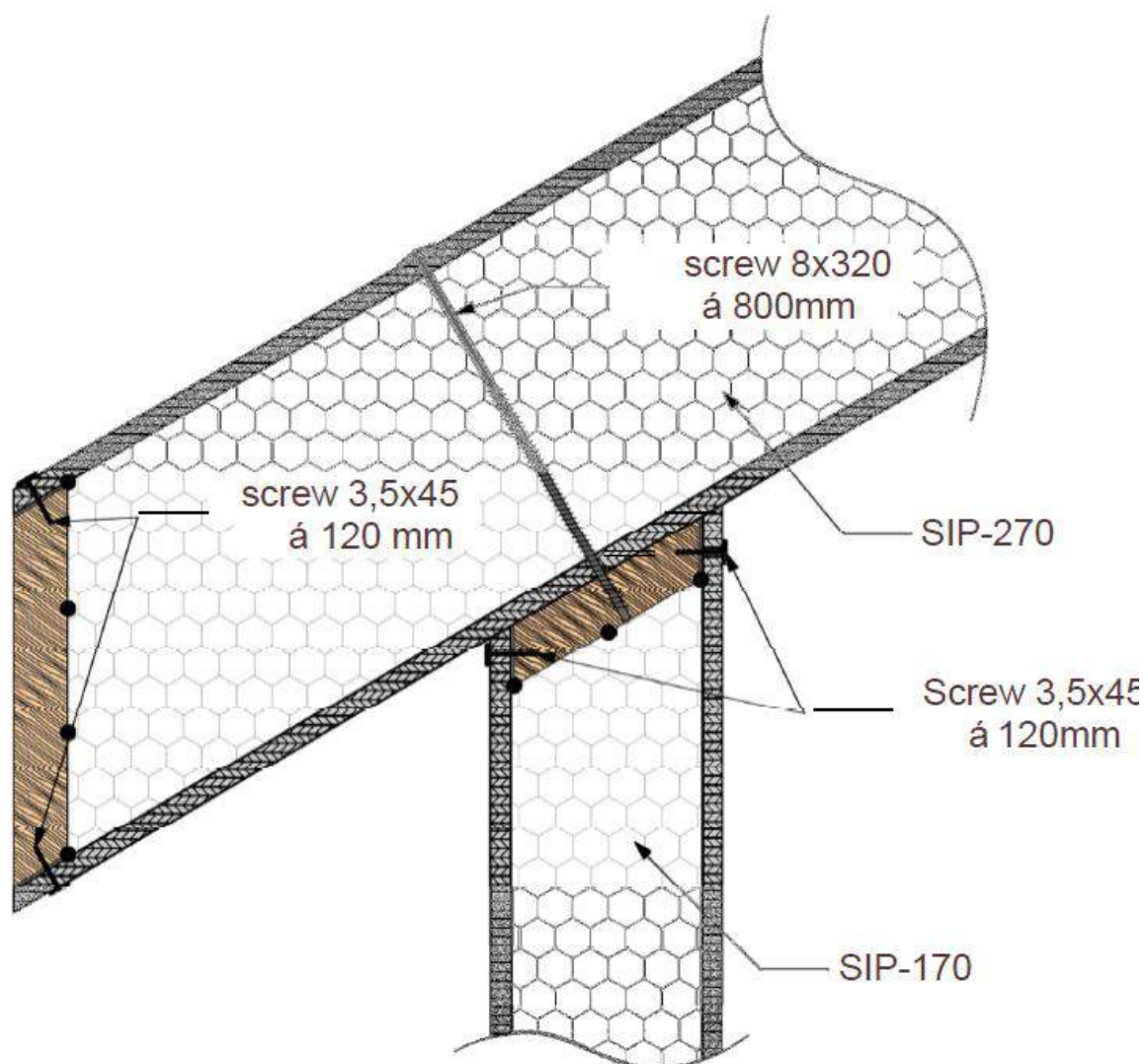

Figure 30 – Joint of the roof panel to wall panel